

PORTAVALIGIA SPECIFICO - SPECIFIC CASE HOLDER
 PORTE-VALISE SP CIFIQUE - SPEZIFISCHER KOFFER-TR GER
 PORTA-EQUIPAJE ESPECCEFICO

BMW R1200GS '04/'08

ISTRUZIONI DI MONTAGGIO - MOUNTING INSTRUCTIONS
 INSTRUCTIONS DE MONTAGE - BAUANLEITUNG - INSTRUCCIONES DE MONTAJE

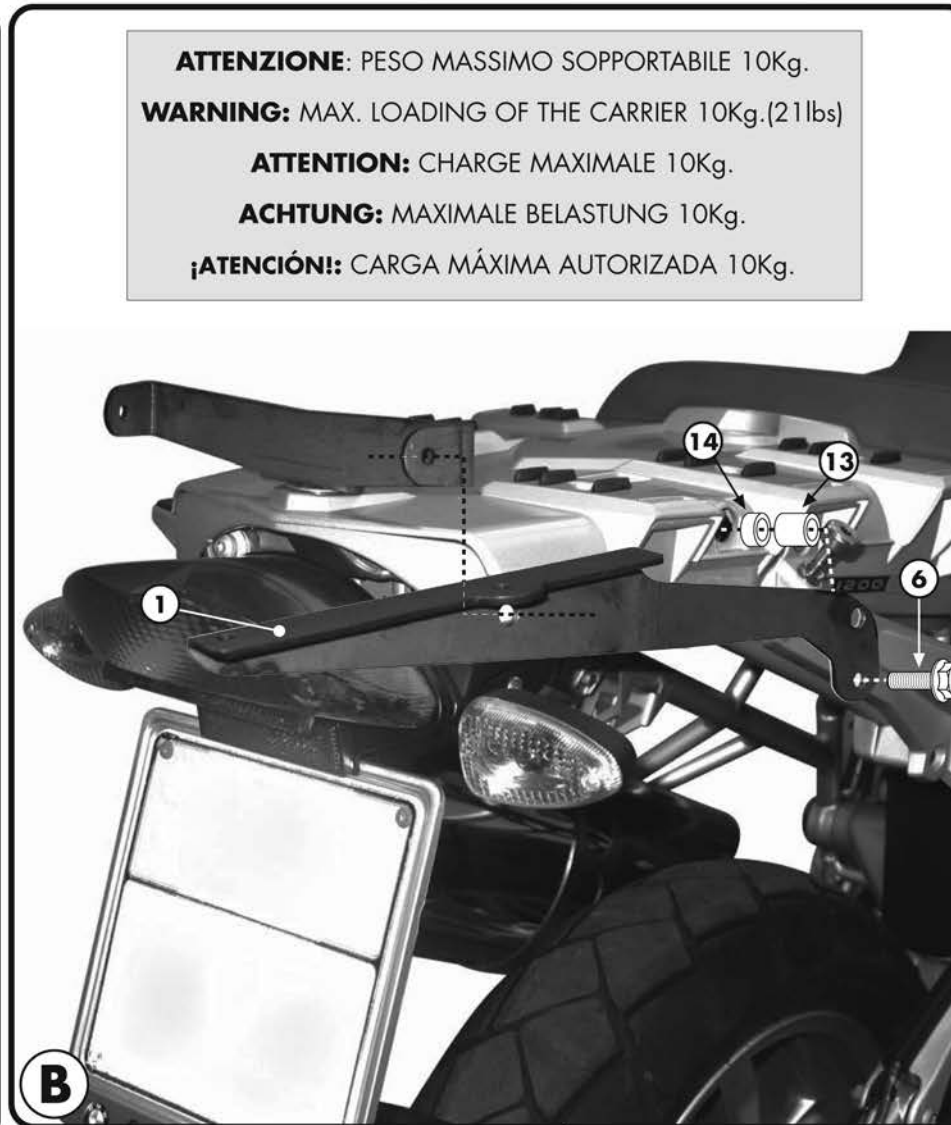
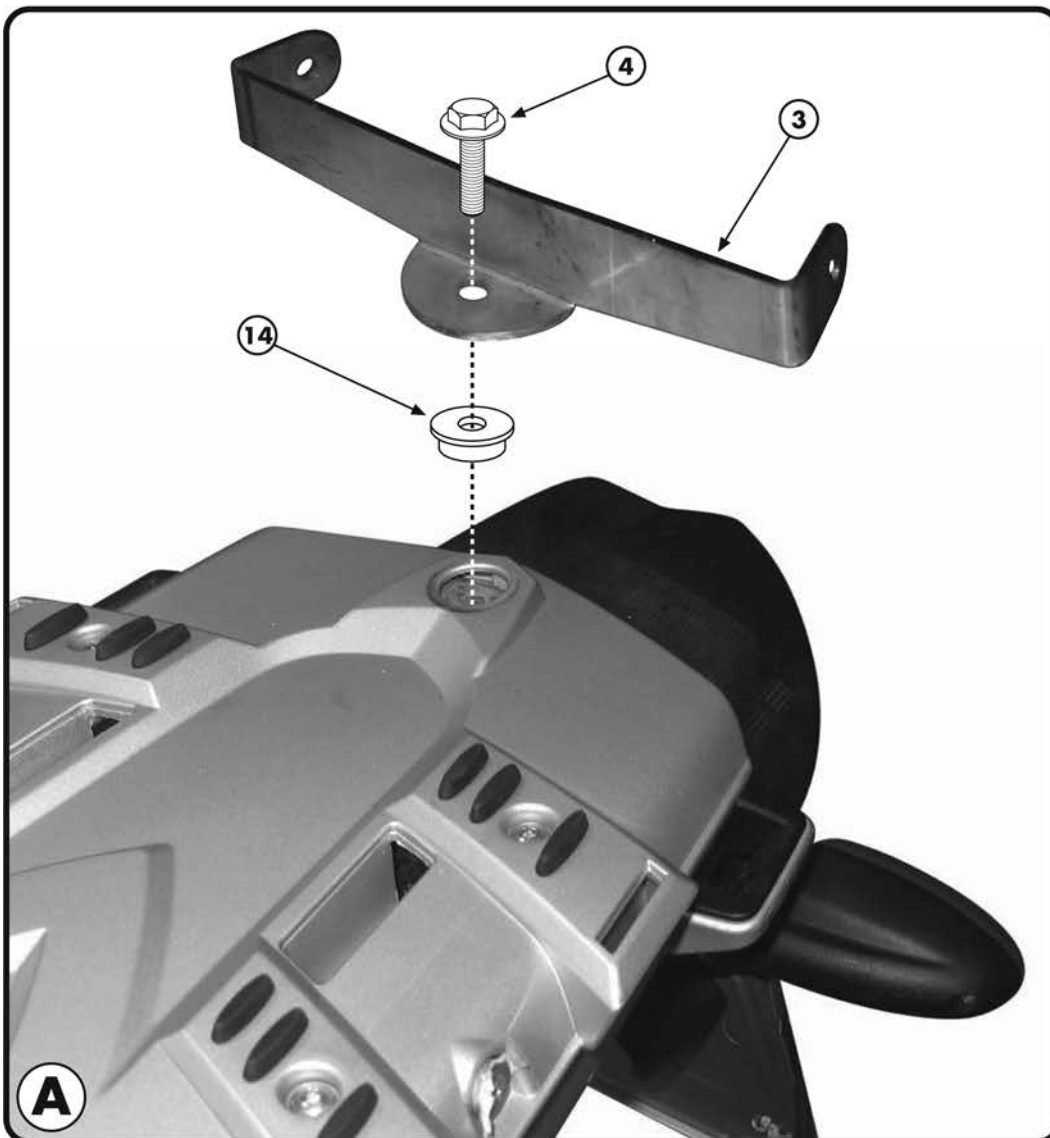

ATTENZIONE: PESO MASSIMO SOPPORTABILE 10Kg.
WARNING: MAX. LOADING OF THE CARRIER 10Kg.(21lbs)
ATTENTION: CHARGE MAXIMALE 10Kg.
ACHTUNG: MAXIMALE BELASTUNG 10Kg.
¡ATENCIÓN!: CARGA MÁXIMA AUTORIZADA 10Kg.

PORTAVALIGIA SPECIFICO - SPECIFIC CASE HOLDER
 PORTE-VALISE SP CIFIQUE - SPEZIFISCHER KOFFER-TR GER
 PORTA-EQUIPAJE ESPECIFICO

BMW R1200GS '04/'08

ISTRUZIONI DI MONTAGGIO - MOUNTING INSTRUCTIONS
 INSTRUCTIONS DE MONTAGE - BAUANLEITUNG - INSTRUCCIONES DE MONTAJE

7



RONDELLA Ø8mm
 WASHER Ø8mm
 RONDELLE Ø8mm
 SCHEIBE Ø8mm
 ARANDELA Ø8mm

Q.TY n.2

8



VITE TCEI M6x35mm
 SCREW
 VIS
 SCHRAUBE
 TORNILLO

Q.TY n.4

9



RONDELLA Ø6mm
 WASHER Ø6mm
 RONDELLE Ø6mm
 SCHEIBE Ø6mm
 ARANDELA Ø6mm

Q.TY n.4

10



RONDELLA f16x20mm
 WASHER
 RONDELLE
 SCHEIBE
 ARANDELA

Q.TY n.4

11



DADO A.B. M6
 BOLT M6
 ECROU M6
 MUTTER M6
 TUERCA M6

Q.TY n.4

12



COPRIFORO
 BOLT CAP
 CACHE TROU
 STOPLOCK
 TAPA AGUJERO

Q.TY n.6

13



DISTANZIALE Ø18x7mm
 Foro Ø8,5mm, V497
 SPACER
 ENTRETOISE
 DISTANZSTÜCK
 DISTANCIADOR

Q.TY n.2

14

COMPONENTI ORIGINALI
 ORIGINAL PARTS
 PARTIES ORIGINALES
 ORIGINAL BAUTEILE
 COMPONENTES ORIGINALES

Q.TY n.-

15



RONDELLA f18x20mm
 WASHER f18x20mm
 RONDELLE f18x20mm
 SCHEIBE f18x20mm
 ARANDELA f18x20mm

Q.TY n.4

16



PIASTRA MONOKEY
 Z622M
 PLATE
 PLATINE
 PLATTE
 PARRILLA

Q.TY n.1

17



RONDELLA f18x14mm
 WASHER f18x14mm
 RONDELLE f18x14mm
 SCHEIBE f18x14mm
 ARANDELA f18x14mm

Q.TY n.2

18



VITE TBEI M8x30mm
 SCREW M8x30mm
 VIS M8x30mm
 SCHRAUBE M8x30mm
 TORNILLO M8x30mm

Q.TY n.2

19



DADO A.B. M8
 BOLT M8
 ECROU M8
 MUTTER M8
 TUERCA M8

Q.TY n.4

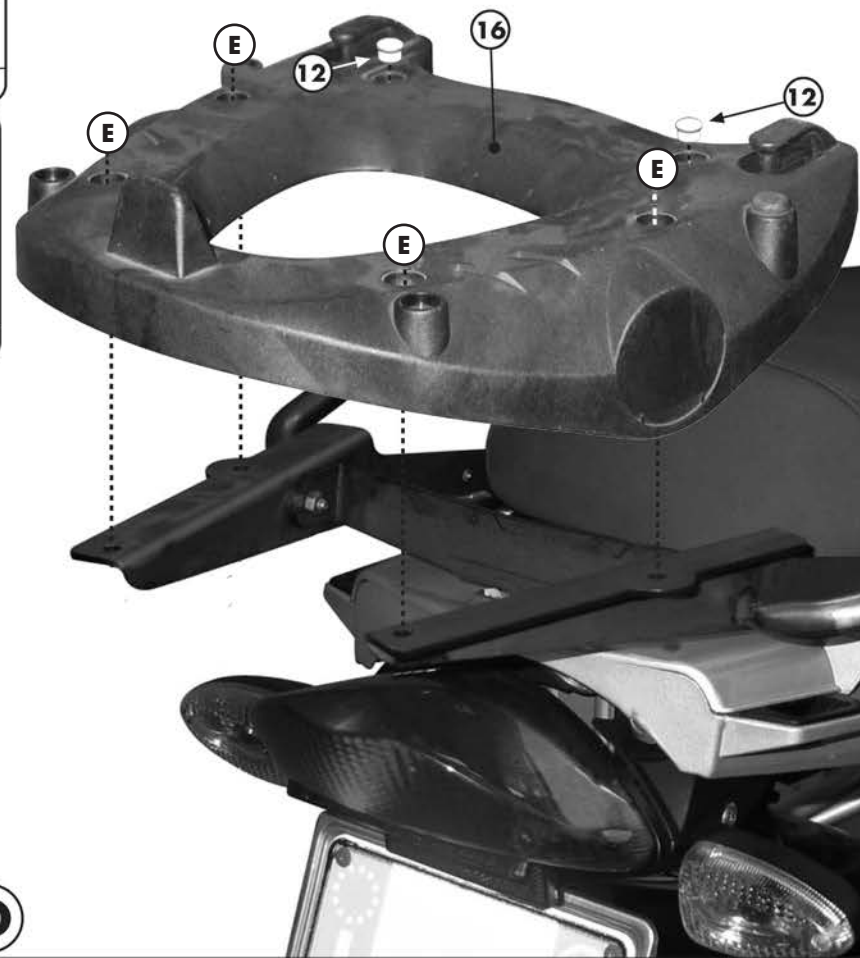
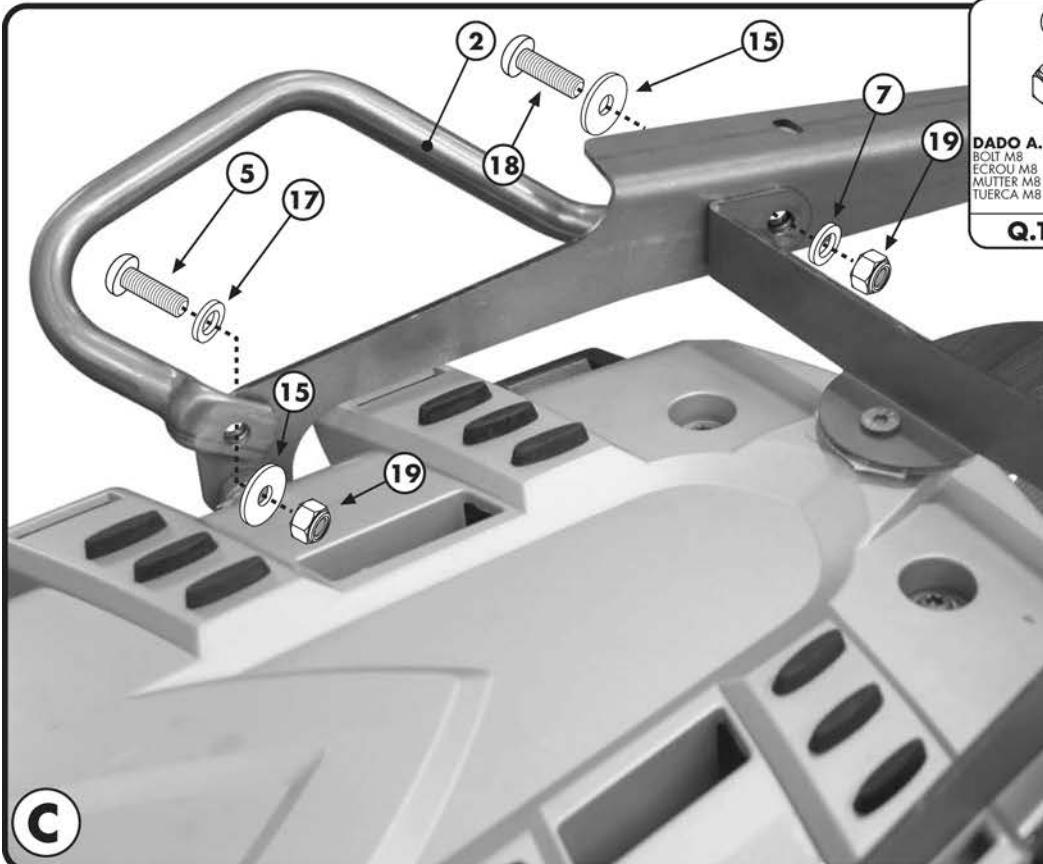

PORTAVALIGIA SPECIFICO - SPECIFIC CASE HOLDER
 PORTE-VALISE SPECIFIQUE - SPEZIFISCHER KOFFER-TRÄGER
 PORTA-EQUIPAJE ESPECÍFICO

BMW R1200GS '04/'08

ISTRUZIONI DI MONTAGGIO - MOUNTING INSTRUCTIONS
 INSTRUCTIONS DE MONTAGE - BAUANLEITUNG - INSTRUCCIONES DE MONTAJE

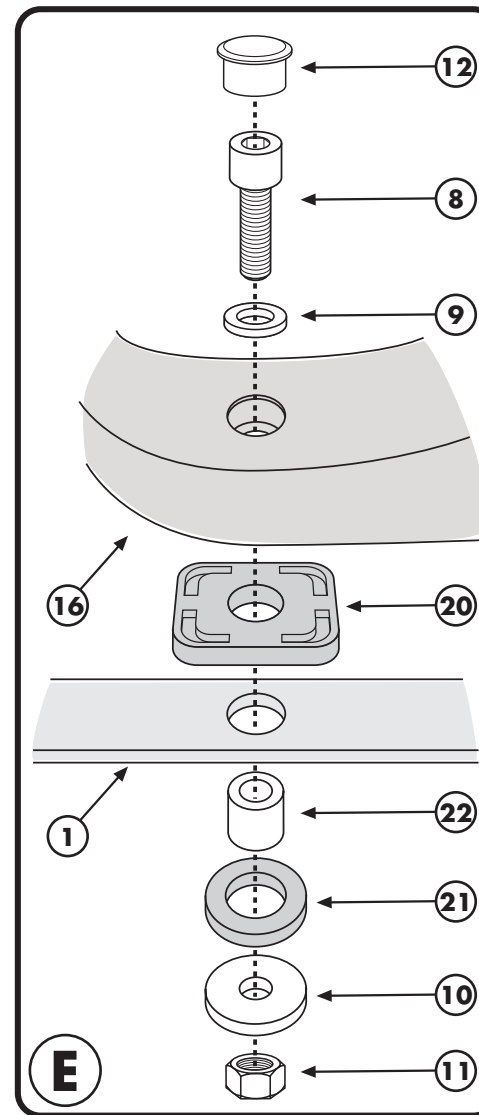
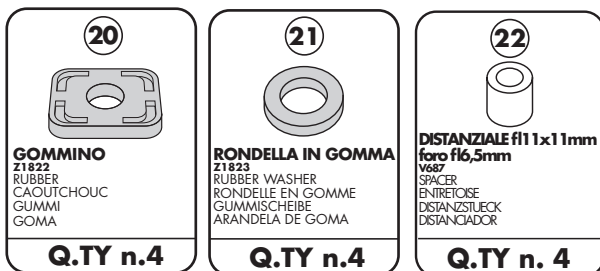

PORTAVALIGIA SPECIFICO - SPECIFIC CASE HOLDER
 PORTE-VALISE SPECIFIQUE - SPEZIFISCHER KOFFER-TR GER
 PORTA-EQUIPAJE ESPECIFICO

BMW R1200GS '04/'08

ISTRUZIONI DI MONTAGGIO - MOUNTING INSTRUCTIONS
 INSTRUCTIONS DE MONTAGE - BAUANLEITUNG - INSTRUCCIONES DE MONTAJE

I ISTRUZIONI DI MONTAGGIO

1. SMONTARE IL PORTAPACCO ORIGINALE; POSIZIONARE IL SUPPORTO POSTERIORE N°3 COME INDICATO IN FOTOGRAFIA A;
2. MONTARE I SUPPORTI N°1 COME INDICATO IN FOTOGRAFIA B;
3. MONTARE LE MANIGLIE, SUPPORTO N°2, COME INDICATO IN FOTOGRAFIA C;
4. MONTARE LA PIASTRA PORTAVALIGIA, PARTICOLARE N°16, COME INDICATO IN FOTOGRAFIA D;
5. ULTIMARE IL MONTAGGIO CONTROLLANDO CHE TUTTE LE VITI SIANO SERRATE BENE

GB MOUNTING INSTRUCTIONS

1. REMOVE THE ORIGINAL CASE CARRIER; THEN POSITION THE REAR SUPPORT N° 3 AS SHOWN IN PICTURE A;
2. MOUNT THE SUPPORTS N° 1 AS SHOWN IN PICTURE B;
3. MOUNT THE HANDLE-BARS, PART N° 2, AS SHOWN IN PICTURE C;
4. NOW MOUNT THE PLATE, PART N° 16, AS SHOWN IN PICTURE D;
5. LASTLY CHECK THAT ALL SCREWS HAVE BEEN TIGHTENED.

F INSTRUCTIONS DE MONTAGE

1. DEMONTER LE SUPPORT TOP CASE D'ORIGINE; POSITIONNER LE SUPPORT POSTERIEUR N.3 COMME INDIQUE EN PHOTO A;
2. MONTER LES SUPPORTS N.1 COMME INDIQUE EN PHOTO B;
3. MONTER LES POIGNEES, PIECES N.2, COMME INDIQUE EN PHOTO C;
4. MONTER LA PLATINE, PIECE N.16, COMME INDIQUE EN PHOTO D;
5. TERMINER LE MONTAGE EN CONTROLANT LE BON SERRAGE DE TOUTES LES VIS.

D BAUANLEITUNG

1. ENTFERNEN SIE DEN ORIGINAL KOFFERTRÄGER; DANN POSITIONIEREN SIE DIE HALTERUNG NR. 3 WIE IM BILD A BESCHRIEBEN;
2. MONTIEREN SIE DIE HALTERUNGEN NR. 1 WIE IM BILD B BESCHRIEBEN;
3. MONTIEREN SIE DIE HANDGRIFFE, HALTERUNG NR. 2, WIE IM BILD C BESCHRIEBEN;
4. MONTIEREN SIE DIE PLATTE, TEIL NR. 16, WIE IM BILD D BESCHRIEBEN;
5. ZULETZT ÜBERPRÜFEN SIE, DASS ALLE SCHRAUBEN FESTGEZOGEN WURDEN.

ES

INSTRUCCIONES DE MONTAJE

1. DESMONTAR EL PORTAEQUIPAJES ORIGINAL; POSICIONAR EL SOPORTE POSTERIOR N° 3 COMO ESTÁ INDICADO EN LA FOTOGRAFÍA "A";
2. MONTAR LOS SOPORTES N° 1 COMO ESTA INDICADO EN LA FOTOGRAFÍA B
3. MONTAR LOS TIRADORES, SOPORTE N° 2 COMO INDICADO EN LA IMAGEN C
4. MONTAR LA PARRILLA PORTAMALETAS, ESPECIFICA N° 16 COMO ESTA INDICADO EN LA FOTOGRAFÍA "D"
5. TERMINAR EL MONTAJE VERIFICANDO QUE TODOS LOS TORNILLOS SE ENCUENTREN BIEN APRETADOS.