

PORTAVALIGIA SPECIFICO - SPECIFIC CASE HOLDER  
 PORTE-VALISE SPECIFIQUE - SPEZIFISCHER KOFFER-TRÄGER  
 PORTA-EQUIPAJE ESPECIFICO - RACK ESPECIFICO

# BMW F650GS 2004

ISTRUZIONI DI MONTAGGIO - MOUNTING INSTRUCTIONS - INSTRUCTIONS DE MONTAGE  
 BAUANLEITUNG - INSTRUCCIONES DE MONTAJE - INSTRUÇÕES DE MONTAGEM

1



SUPPORTO PIASTRA  
 PLATE SUPPORT  
 SUPPORT PLATINE  
 PLATTEHALTERUNG  
 SOPORTE PARRILLA  
 SUPORTE PIASTRA

Q.TY n.1

2



SUPPORTO  
 SUPPORT  
 SUPPORT  
 HALTERUNG  
 SOPORTE  
 SUPORTE

Q.TY n.2(Dx-Sx)

3



VITE TSCEI M6x60mm  
 SCREW M6x60mm  
 VIS M6x60mm  
 SCHRAUBE M6x60mm  
 TORNILLO M6x60mm  
 PARAFUSO M6x60mm

Q.TY n.4

4

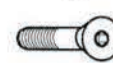

VITE TSCEI M6x16mm  
 SCREW M6x16mm  
 VIS M6x16mm  
 SCHRAUBE M6x16mm  
 TORNILLO M6x16mm  
 PARAFUSO M6x16mm

Q.TY n.2

5



VITE TBEI M8x20mm  
 SCREW M8x20mm  
 VIS M8x20mm  
 SCHRAUBE M8x20mm  
 TORNILLO M8x20mm  
 PARAFUSO M8x20mm

Q.TY n.2

6



RONDELLA Ø8x14mm  
 WASHER Ø8x14mm  
 RONDELLE Ø8x14mm  
 SCHEIBE Ø8x14mm  
 ARANDELA Ø8x14mm  
 ARRUELA Ø8x14mm

Q.TY n.2

7



V004

DISTANZIALE Ø16x4mm  
 foro Ø8,5mm  
 SPACER  
 ENTRETOISE  
 DISTANZSTUECK  
 DISTANCIADOR  
 DISTANCIADOR

Q.TY n.2

8



V549

DISTANZIALE 16x22mm  
 foro Ø8,5mm  
 SPACER  
 ENTRETOISE  
 DISTANZSTUECK  
 DISTANCIADOR  
 DISTANCIADOR

Q.TY n.4

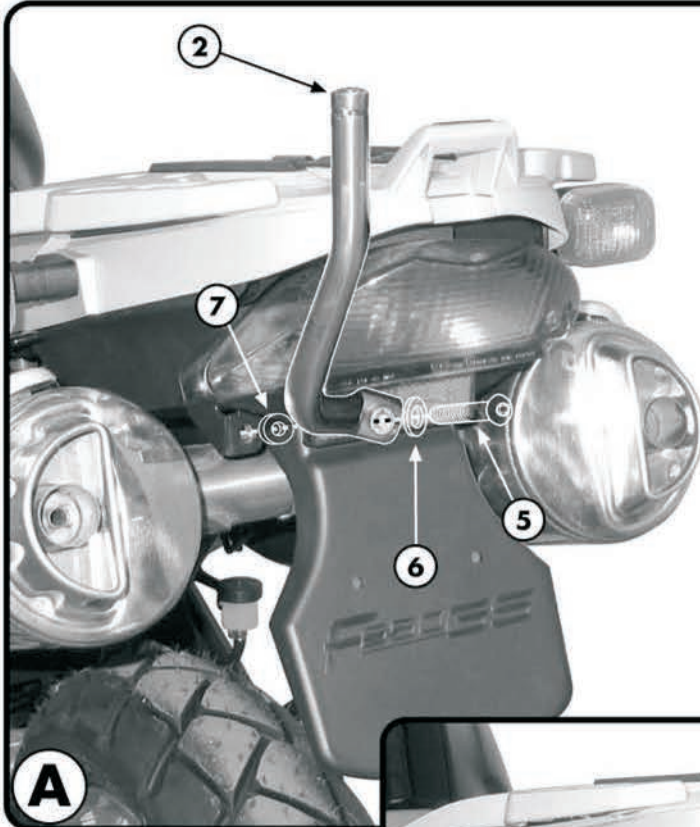

A

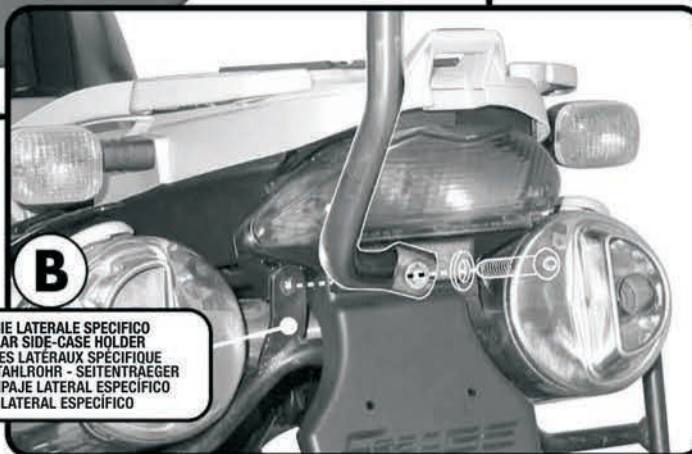

B

PIASTRA SPECIFICA + PORTAVALIGIE LATERALE SPECIFICO  
 SPECIFIC PLATE + SPECIFIC TUBULAR SIDE-CASE HOLDER  
 PLATINE SPECIFIQUE + PORTE-VALISES LATÉRAUX SPECIFIQUE  
 SPEZIFISCHE PLATTE + SPEZIFISCHES STAHLROHR - SEITENTRÄGER  
 PARRILLA ESPECIFICA + PORTA-EQUIPAJE LATERAL ESPECIFICO  
 BASE ESPECIFICA + SUPORTE LATERAL ESPECIFICO

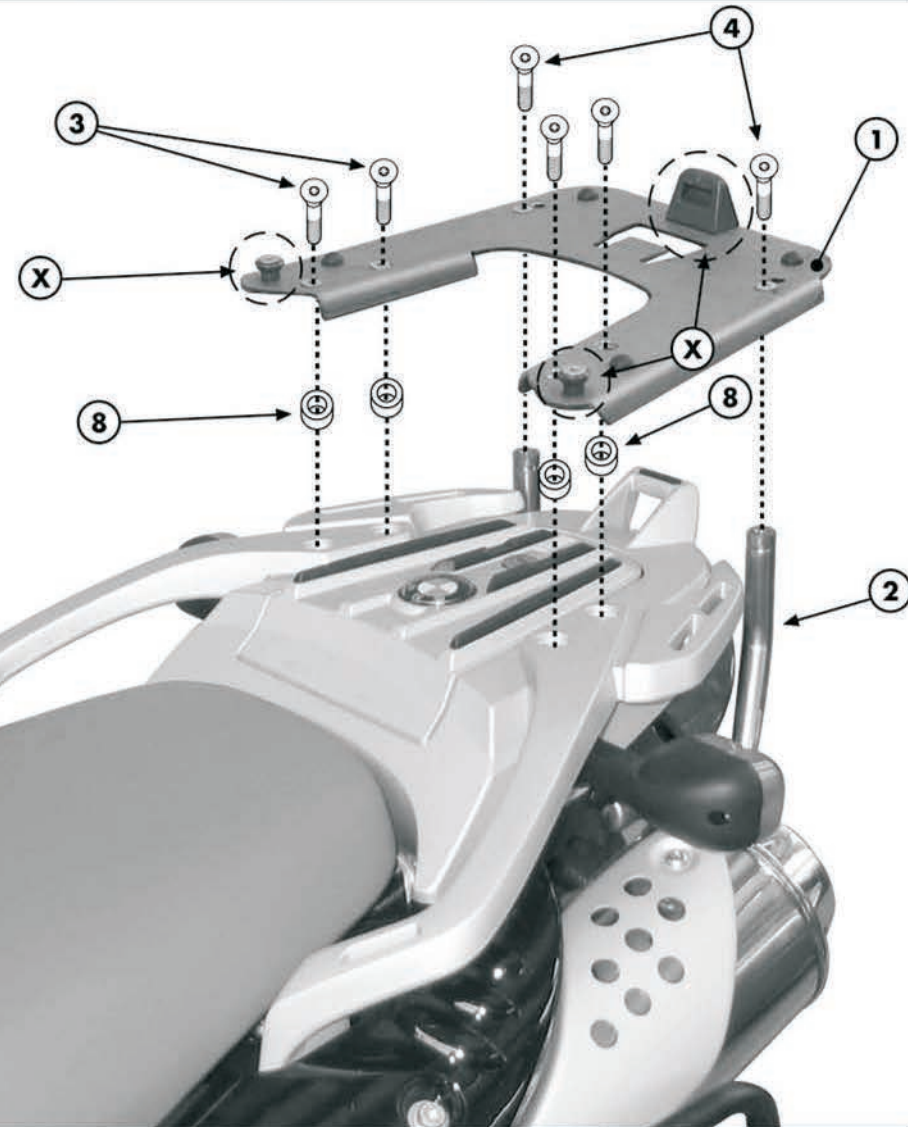

C



PORTAVALIGIA SPECIFICO - SPECIFIC CASE HOLDER  
 PORTE-VALISE SPECIFIQUE - SPEZIFISCHER KOFFER-TRÄGER  
 PORTA-EQUIPAJE ESPECIFICO - RACK ESPECIFICO

**BMW F650GS 2004**

ISTRUZIONI DI MONTAGGIO - MOUNTING INSTRUCTIONS - INSTRUCTIONS DE MONTAGE  
 BAUANLEITUNG - INSTRUCCIONES DE MONTAJE - INSTRUÇÕES DE MONTAGEM

## I ISTRUZIONI DI MONTAGGIO

1. POSIZIONARE I SUPPORTI N°2 COME INDICATO IN FOTO A;
2. FAR RIFERIMENTO ALLA FOTO B NEL CASO SI VOGLIA MONTARE IL PORTAVALIGIA CENTRALE IN ABBINAMENTO AL PORTAVALIGIE LATERALE;
3. CONTROLLARE CHE LE VITI DEI PARTICOLARI INDICATI CON LA LETTERA X, EVIDENZIATI IN FOTO C, SIANO SERRATE BENE;
4. POSIZIONARE E FISSARE LA PIASTRA N°1 COME INDICATO IN FOTO C;
5. ULTIMARE IL MONTAGGIO CONTROLLANDO CHE TUTTE LE VITI SIANO SERRATE BENE.

## GB MOUNTING INSTRUCTIONS

1. LACE THE SUPPORTS N°2 AS SHOWN IN PICTURE A;
2. MAKE REFERENCE TO PICTURE B IF YOU WANT TO MOUNT THE TOPCASE HOLDER TOGETHER WITH THE SIDE-CASE HOLDER;
3. CHECK THAT THE SCREWS INDICATED WITH THE LETTER X IN PICTURE C HAVE BEEN TIGHTENED;
4. PLACE AND FIX THE PLATE N° 1 AS SHOWN IN PICTURE C;
5. LASTLY CHECK THAT ALL SCREWS HAVE BEEN TIGHTENED.

## F INSTRUCTIONS DE MONTAGE

1. POSITIONNER LES SUPPORTS N° 2 COMME INDIQUE SUR LA PHOTO A;
2. SE REFERER A LA PHOTO B DANS LE CAS D'UN MONTAGE COMBINE AVEC LES SUPPORTS VALISES;
3. CONTROLER LE BON SERRAGE DES VIS DES PIECES INDIQUEES AVEC LA LETTRE X SUR LA PHOTO C;
4. POSITIONNER ET FIXER LA PLATINE N° 1 CIMME INDIQUE SUR LA PHOTO C;
5. TERMINER LE MONTAGE EN CONTROLANT LE BON SERRAGE DE TOUTES LES VIS.

## D BAUANLEITUNG

1. POSITIONIEREN SIE DIE HALTERUNGEN NR. 2 WIE IM BILD A BESCHRIEBEN;
2. NEHMEN SIE AUF DAS BILD B BEZUG FALLS SIE DEN TOPCASE -TRÄGER MIT DEN SEITENKOFFERTRÄGER MONTIEREN MÖCHTEN;
3. ÜBERPRÜFEN SIE OB ALLÉ MIT X GEKENNZEICHNETEN SCHRAUBEN WIE IM BILD C FESTGEZOGEN SIND.
4. POSITIONIEREN UND BEFESTIGEN SIE DIE PLATTE NR. 1 WIE IM BILD C BESCHRIEBEN;
5. ZULETZT ZIEHEN SIE ALLE SCHRAUBEN FEST.

## ES INSTRUCCIONES DE MONTAJE

1. A. MONTAJE SIN EL PORTA MALETAS LATERAL:  
MONTAR LOS SOPORTES N° 2 COMO INDICA LA FOTO A;
1. B. MONTAJE COMBINANDO CON EL PORTA MALETAS LATERAL:  
SEGUIR LAS INDICACIONES DE LA FOTO B;
- INDICADOS POR LA LETRA X COMO INDICA LA FOTO C;
2. CONTROLAR QUE SE HAN APRETADO TODOS LOS TORNILLOS
3. MONTAR Y ANCLAR LA PLETINA N° 1 COMO INDICA LA FOTO C;
4. TERMINAR APRETANDO TODOS LOS TORNILLOS.

## P

1. POSICIONE OS SUPORTES N°2 CONFORME DEMONSTRADO NA FIGURA A;
2. UTILIZE COMO REFERÊNCIA A FIGURA B, SE VOCÊ DESEJA MONTAR O SUPORTE TRASEIRO EM CONJUNTO COM O SUPORTE LATERAL DE BAÚ;
3. CERTIFIQUE QUE TODOS OS PARAFUSOS INDICADOS COM A LETRA X NA FIGURA C FORAM FIXADOS;
4. POSICIONE E REALIZE A FIXAÇÃO DA PLACA N°1 CONFORME DEMONSTRADO NA FIGURA C;
5. POR ULTIMO, VERIFIQUE SE TODOS OS PARAFUSOS FORAM BEM APERTADOS.