

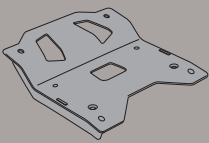

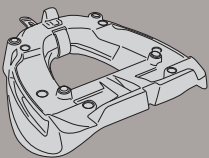







# SR4111MM - KR4111MM

PORTAPACCO SPECIFICO - SPECIFIC HOLDER - PORTE-PAQUET SPÉCIFIQUE - SPEZIFISCHER TRÄGER - PORTA-EQUIPAJE ESPECÍFICO - TRANSPORTADOR ESPECÍFICO

## KAWASAKI J300i (2014)

| N° | Descrizione  | Caratteristiche   | Codice     | Quantità |   |
|----|--|-------------------|------------|----------|---|
| 1  | Supporto - Support - Support<br>Halierung - Soporte - Apoio                        | Sp. 3mm           | GL2595     | 1        |    |
| 2  | Piastra - Plate<br>Platine - Platte<br>Parrilla - Grelha                           | -                 | M6M        | 1        |    |
| 3  | Vite - Screw<br>Vis - Schraube<br>Tornillo - Parafuso                              | TEF M6x50         | 650TECF    | 2        |    |
| 4  | Vite - Screw<br>Vis - Schraube<br>Tornillo - Parafuso                              | TEF M6x55         | 655TSP     | 2        |    |
| 5  | Vite - Screw<br>Vis - Schraube<br>Tornillo - Parafuso                              | TCEI M6x25        | 625TCE     | 4        |   |
| 6  | Distanziale - Spacer<br>Entretoise - Distanzstueck<br>Distanciador - Espaçador     | Ø18x30 Foro 9,5mm | C18L30F9,5 | 2        |  |
| 7  | Distanziale - Spacer<br>Entretoise - Distanzstueck<br>Distanciador - Espaçador     | Ø18x32 Foro 8,5mm | C18L32F8,5 | 2        |  |
| 8  | Rondella - Washer<br>Rondelle - Scheibe<br>Arandela - Arruela                      | Ø6                | 6RON       | 4        |  |
| 9  | Rondella - Washer<br>Rondelle - Scheibe<br>Arandela - Arruela                      | Ø6x18             | 618RON     | 4        |  |
| 10 | Dado - Bolt - Ecrou<br>Mutter - Tuerca - Porca                                     | Auto Bloccante M6 | 6DADIAU    | 4        |  |
| 11 | Copriforo - Bolt Cap<br>Cache Trou - Stopslock<br>Tapa Agujero - Tampa do Orificio | -                 | Z621       | 6        |  |

# SR4111MM - KR4111MM

PORTAPACCO SPECIFICO - SPECIFIC HOLDER - PORTE-PAQUET SPÉCIFIQUE - SPEZIFISCHER TRÄGER - PORTA-EQUIPAJE ESPECÍFICO - TRANSPORTADOR ESPECÍFICO

## KAWASAKI J300i (2014)

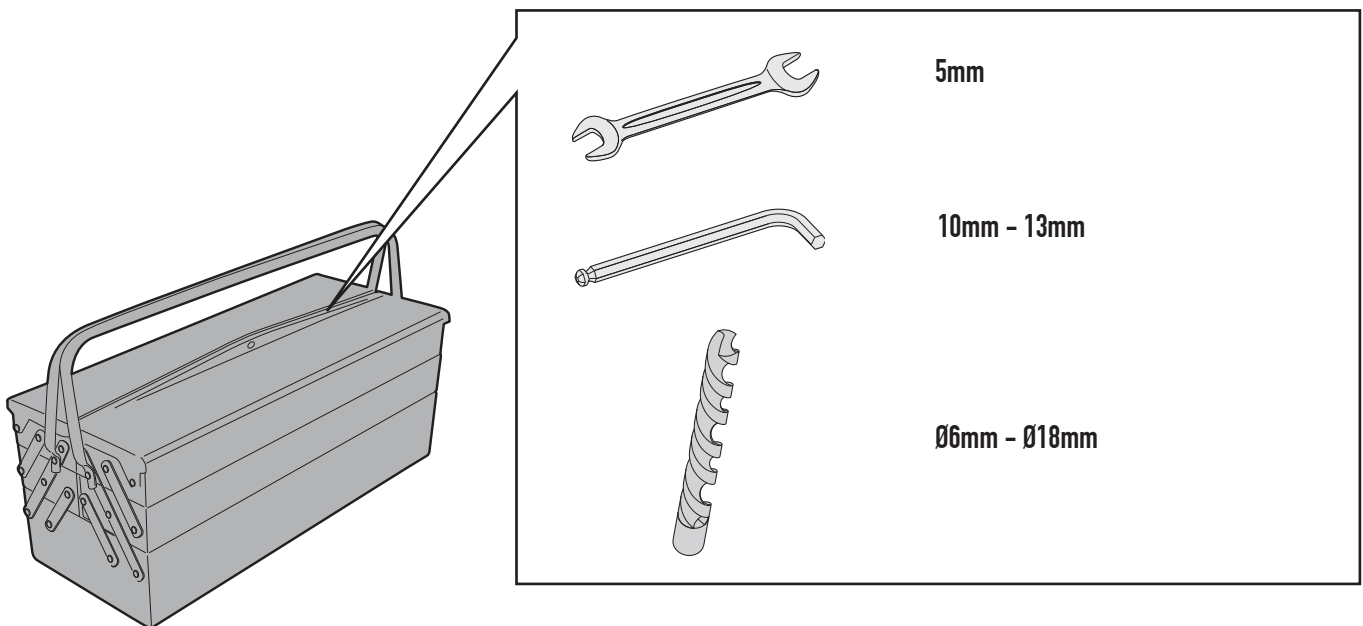

# SR411MM - KR411MM

PORTAPACCO SPECIFICO - SPECIFIC HOLDER - PORTE-PAQUET SPÉCIFIQUE - SPEZIFISCHER TRÄGER - PORTA-EQUIPAJE ESPECÍFICO - TRANSPORTADOR ESPECÍFICO

## KAWASAKI J300i (2014)

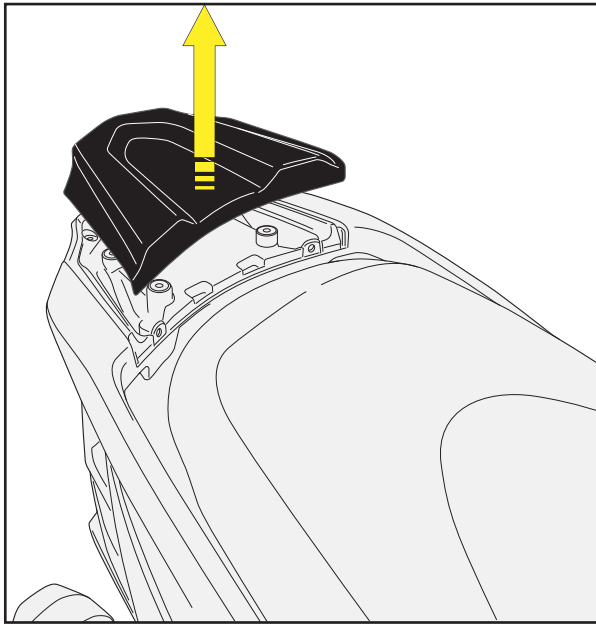

TOGLIERE

REMOVE

ENLEVER

ENTFERNEN

QUITAR

REMOVED

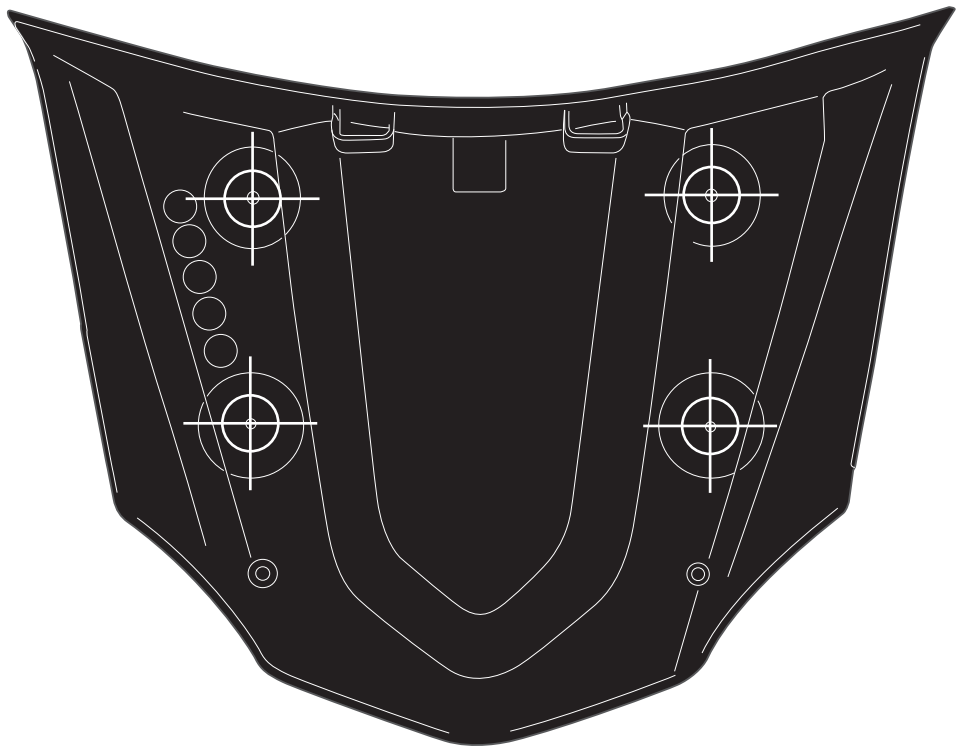
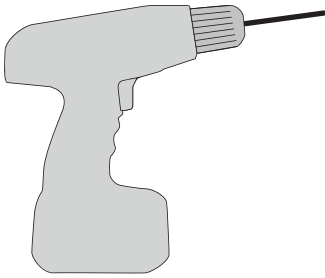

. FORARE NEI 4 PUNTI INDICATI; FORARE PRIMA CON UNA PUNTA PICCOLA ( $\varnothing 6$ ), POI ALLARGARLI CON UNA PUNTA DA 18MM.

. PIERCE THE 4 POINTS MARKED; START WITH A SMALL POINT ( $\varnothing 6$ ) AND CHECK THE POINTS ARE LINED UP WITH THE ORIGINAL SCREWS BELOW; THEN ENLARGE THE HOLES WITH A  $\varnothing 18$  POINT.

. PERCER LES 4 POINTS INDIQUE EN COMMENCANT AVEC UN FORET 6MM, VERIFIER QU'ILS SONT A LIGNE AVEC LES VIS ORIGINALES DESSOUS, POIS AGGRANDIR LES TROUS AVEC UN FORET DE 18MM.

MIT EINEM 6MM BOHRER VORBOHREN; DANN ÜBERPRÜFEN OB DIE BOHRUGEN MIT DEN ORIGINALSCHRAUBEN MITTING SIND; JETZT DIE LOCHER AUF 18MM AUFBOHREN.

. AGUJERAR EN LOS 4 PUNTOS INDICADOS; AGUJERAR PRIMERO CON LA PUNTA PEQUENA ( $\varnothing 6$ MM), CONTROLAR QUE CONICIDAN CON LOS TORNILLOS QUE SE ENCUENTRAN EN EL CHASIS DE LA MOTO, LUEGO AMPLIAR EL AGUJERO CON UNA PUNTA DE 18MM.

. AGUJERAR EN LOS 4 PUNTOS INDICADOS; LUEGO EL AMPLIAR AGUJERO CON UN POCO DE 18 MILÍMETROS.

ISTRUZIONI DI MONTAGGIO - MOUNTING INSTRUCTIONS  
INSTRUCTIONS DE MONTAGE - BAUANLEITUNG  
INSTRUCCIONES DE MONTAJE - INSTRUÇÕES DE MONTAGEM

# SR4111MM - KR4111MM

PORTAPACCO SPECIFICO - SPECIFIC HOLDER - PORTE-PAQUET SPECIFIQUE - SPEZIFISCHER TRÄGER - PORTA-EQUIPAJE ESPECÍFICO - TRANSPORTADOR ESPECÍFICO

## KAWASAKI J300i (2014)

