

PORTAPACCO SPECIFICO - SPECIFIC HOLDER
 PORTE-PAQUET SPECIFIQUE - SPEZIFISCHER TRÄGER
 PORTA-EQUIPAJE ESPECIFICO

YAMAHA X-MAX 125-250 2010

ISTRUZIONI DI MONTAGGIO - MOUNTING INSTRUCTIONS
 INSTRUCTIONS DE MONTAGE - BAUANLEITUNG - INSTRUCCIONES DE MONTAJE

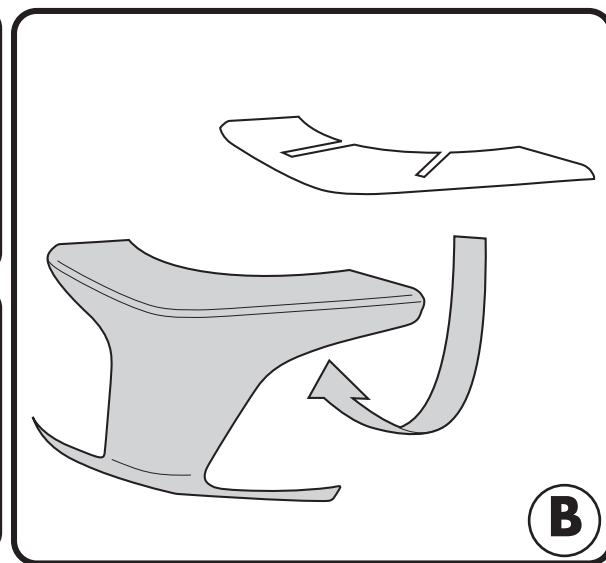
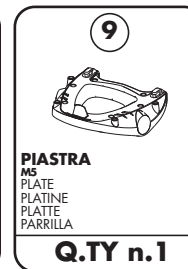
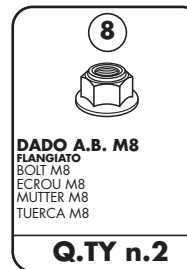
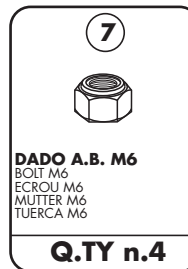
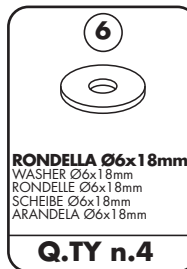
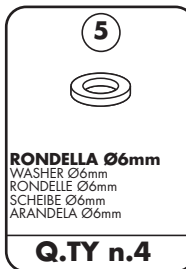
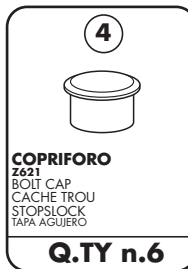
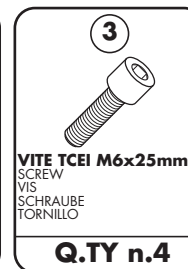
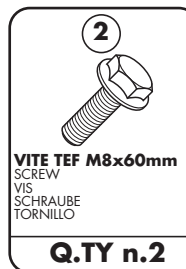

ATTENZIONE: CARICO MASSIMO 6Kg
WARNING: MAX LOAD, 6Kg.
ATENCIÓN: CARGA MÁXIMA, 6Kg.
ACHTUNG: MAX, 6Kg.
¡ATENCIÓN!: CARGA MÁXIMA, 6Kg.

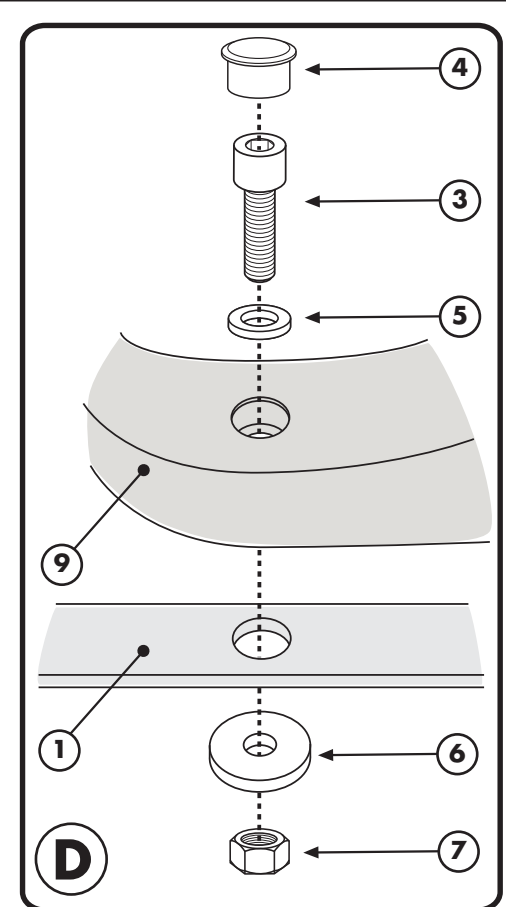
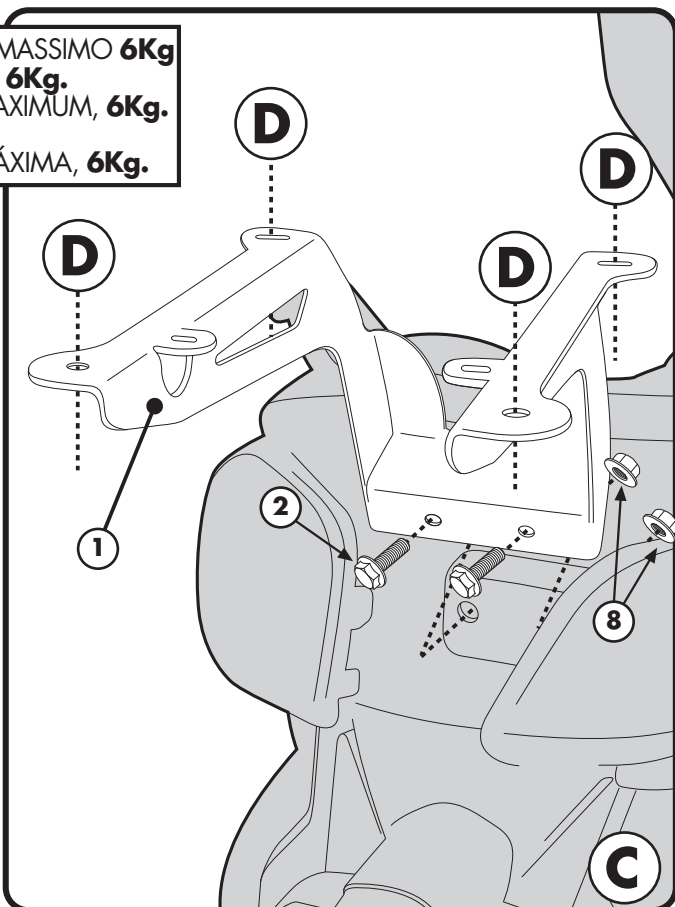
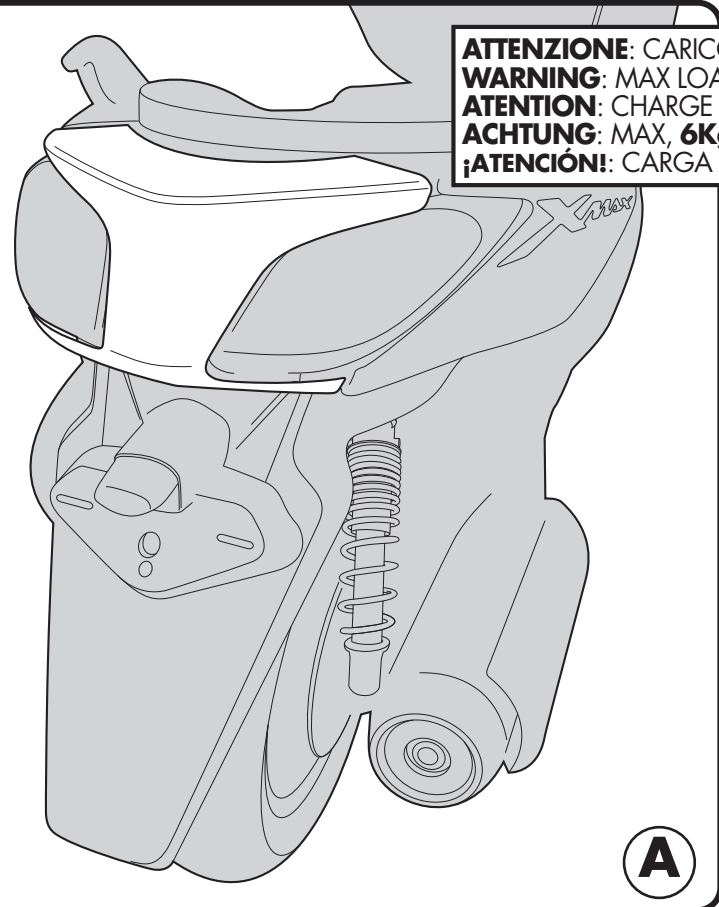

PORTAPACCO SPECIFICO - SPECIFIC HOLDER
PORTE-PAQUET SPÉCIFIQUE - SPEZIFISCHER TRÄGER
PORTA-EQUIPAJE ESPECÍFICO

YAMAHA X-MAX 125-250 2010

ISTRUZIONI DI MONTAGGIO - MOUNTING INSTRUCTIONS
INSTRUCTIONS DE MONTAGE - BAUANLEITUNG - INSTRUCCIONES DE MONTAJE

PRIMA DI TAGLIARE VERIFICARE CHE LA DIMA
CORRISPONDA ALLE MISURE INDICATE

BEFORE DRILLING HOLES CHECK THAT MEASURES ON
TEMPLATE CORRESPOND

AVANT DE PERCER CONTROLER QUE LE GABARIT
CORRESPOND AUX MESURES INDIQUEE

BEVOR DER KOFFERDECKEL DURCHBOHRT WIRD,
PRÜFEN SIE DAß DIE SCHABLONE DEN GEGEBENEN
ABMESSUNGEN ENTSPRICHT

ANTES DE HACER LOS AGUJEROS COMPROBAR LAS
MEDIDAS DE LA PLANTILLA CORRESPONIENTE

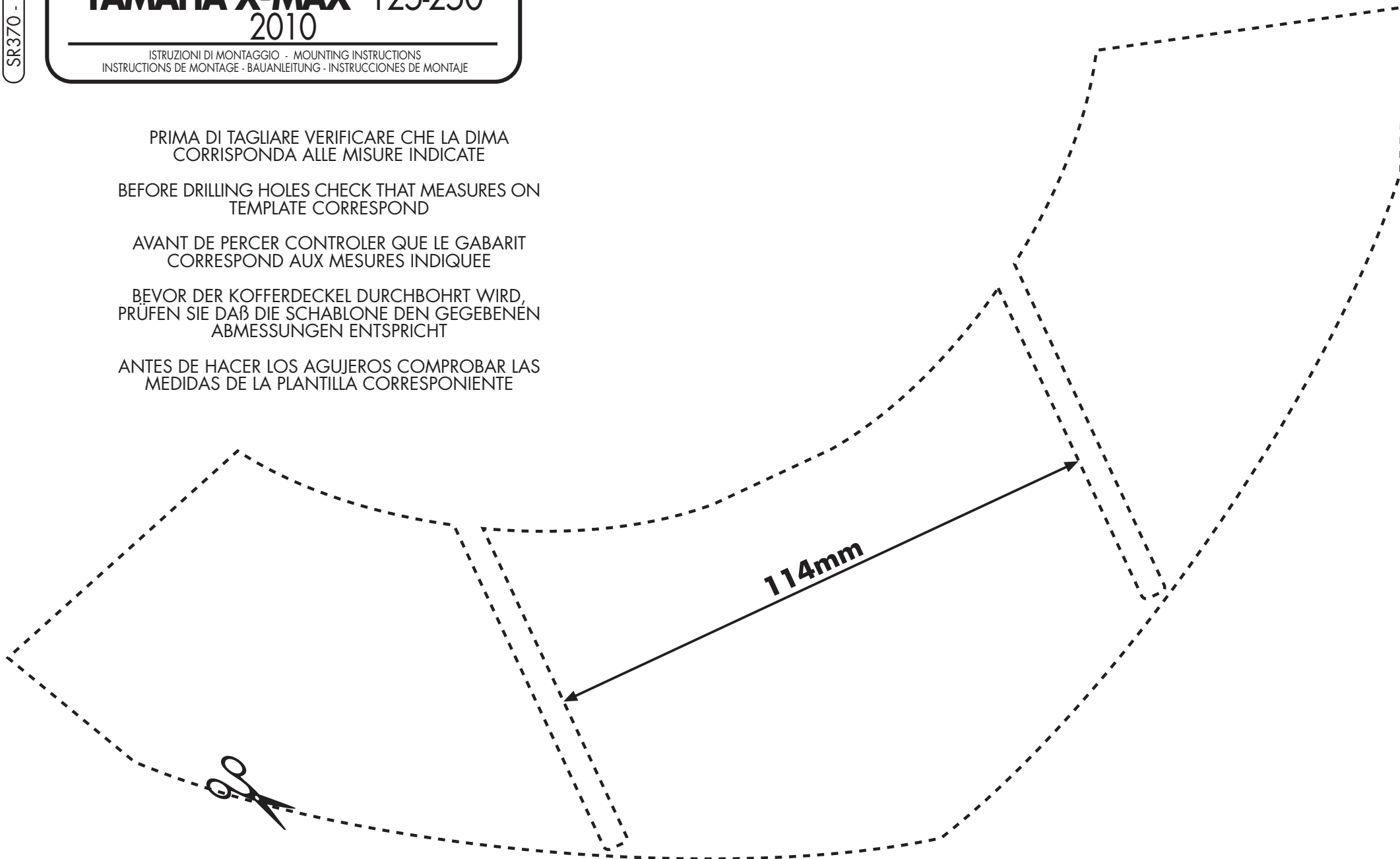

PORTAPACCO SPECIFICO - SPECIFIC HOLDER
 PORTE-PAQUET SPÉCIFIQUE - SPEZIFISCHER TRÄGER
 PORTA-EQUIPAJE ESPECÍFICO

YAMAHA X-MAX 125-250 2010

ISTRUZIONI DI MONTAGGIO - MOUNTING INSTRUCTIONS
 INSTRUCTIONS DE MONTAGE - BAUANLEITUNG - INSTRUCCIONES DE MONTAJE

I ISTRUZIONI DI MONTAGGIO

1. RIMUOVRE IL CARTERINO POSTERIORE ORIGINALE DELLO SCOOTER;
2. RITAGLIARE LA DIMA DAL FOGLIO 2/3 DELL'ISTRUZIONE;
3. POSIZIONARE LA DIMA SOTTO IL CARTERINO ORIGINALE (VEDI FIG. B) E TAGLIARE IN CORRISPONDENZA DELLE 2 LINEE;
4. MONTARE IL SUPPORTO N°1 COME INDICATO IN FIGURA C, RIPOSIZIONARE IL CARTERINO;
5. MONTARE LA PIASTRA COME INDICATO IN FIG. D;
6. ULTIMARE IL MONTAGGIO VERIFICANDO CHE TUTTE LE VITI SIANO SERRATE BENE (VITI M6=9,6Nm - VITI M8=23Nm).

GB MOUNTING INSTRUCTIONS

1. REMOVE THE ORIGINAL REAR COVER OF THE SCOOTER;
2. CUT THE TEMPLATE FROM PAGE 2 OF THE MOUNTING INSTRUCTION;
3. POSITIONING THE TEMPLATE IN THE ORIGINAL COVER (SEE THE PICTURE B) AND CUT IN CORRESPONDENCE TO THE 2 LINES;
4. MOUNT THE NO. 1 SUPPORT AS SHOWN IN THE PICTURE C, AND REPOSITION THE COVER;
5. MOUNT THE PLATE AS SHOWN IN THE PICTURE D;
6. FINISH THE MOUNTING CHECKING THAT ALL THE SCREWS ARE TIGHTENED (M6 = 9.6 NM SCREWS - M8 = 23NM SCREWS).

F INSTRUCTIONS DE MONTAGE

1. ENLEVER LE CARTER POSTERIEUR D'ORIGINE DU SCOOTER
2. DECOUPER LE GABARIT DE LA FEUILLE 2/3 DES INSTRUCTIONS
3. POSITIONNER LE GABARIT SOUS LE CARTER D'ORIGINE (VOIR PHOTO B) ET COUPER EN CORRESPONDANCE DES 2 LIGNES
4. MONTER LE SUPPORT N° COMME INDIQUE EN PHOTO C ; REMETTRE LE CARTER
5. MONTER LA PLATINE COMME INDIQUE EN PHOTO D ;
6. COMPLETER LE MONTAGE EN VÉRIFIANT QUE TOUTES LES VIS SOIENT BIEN FERMÉES (VIS M6=9,6NM - VIS M8=23NM)

D BAUANLEITUNG

1. ENTFERNEN SIE DAS HINTERE ORIGINALGEHÄUSE DES ROLLERS;
2. SCHNEIDEN SIE DIE SCHABLONE AUF SEITE 2/3 DER ANBAUANLEITUNGEN AUS;
3. POSITIONIEREN SIE DIE SCHABLONE AUF DEM ORIGINALGEHÄUSE (BILD B) UND SCHNEIDEN SIE ENTLANG DER ZWEI LINIEN;
4. MONTIEREN SIE DIE HALTERUNG N1 WIE IM BILD C GEZEIGT UND BAUEN SIE DAS GEHÄUSE WIEDER AN;
5. MONTIEREN SIE DIE PLATTE WIE IM BILD D GEZEIGT;
6. ZULETZT ÜBERPRFEN SIE, DASS ALLE SCHRAUBEN (SCHRAUBEN M6=9,6NM SCHRAUBEN M8=23NM) FESTGEZOGEN WURDEN.

ES INSTRUCCIONES DE MONTAJE

1. DESMONTAR LA TAPA ORIGINAL POSTERIOR DEL SCOOTER
2. RECORTAR LA PLANTILLA DE LA HOJA 2/3 DE LAS INSTRUCCIONES
3. POSICIONAR LA PLANTILLA DEBAJO LA TAPA ORIGINAL (VER FOTO B) Y CORTAR SIGUIENDO LAS DOS LINEAS.
4. MONTAR EL SOPORTE N°1 COMO SE INDICA EN LA FOTO C, VOLVER A PONER LA TAPA.
5. MONTAR LA PARRILLA COMO SE MUESTRA EN LA FOTO D
6. TERMINAR EL MONTAJE VERIFICANDO QUE TODOS LOS TORNILLOS ESTÉN BIEN APRETADOS (TORNILLOS M6=9,6 NM – TORNILLOS M8=23 NM)