

PORTAVALIGIA SPECIFICO - SPECIFIC CASE HOLDER
 PORTE-VALISE SPÉCIFIQUE - SPEZIFISCHER KOFFER-TRÄGER
 PORTA-EQUIPAJE ESPECÍFICO

YAMAHA XT660R '04-'06
YAMAHA XT660X '04-'06

ISTRUZIONI DI MONTAGGIO - MOUNTING INSTRUCTIONS
 INSTRUCTIONS DE MONTAGE - BAUANLEITUNG - INSTRUCCIONES DE MONTAJE

1



SUPPORTO PIASTRA
 PLATE SUPPORT
 SUPPORT PLATINE
 PLATTEHALTERUNG
 SOPORTE PLETINA

Q.TY n.2(Dx-Sx)

2



VITE TCEI M8x35mm
 SCREW M8x35mm
 VIS M8x35mm
 SCHRAUBE M8x35mm
 TORNILLO M8x35mm

Q.TY n.4

3



DISTANZIALE Ø18x13
 ribass Ø14x4mm
 foro 8,5mm
 SPACER
 ENTRETÔISE
 DISTANZSTÜCK
 DISTANCIADOR

Q.TY n. 2

4



RONDELLA Ø8mm
 WASHER Ø8mm
 RONDELLE Ø8mm
 SCHEIBE Ø8mm
 ARANDELA Ø8mm

Q.TY n.2

5



PIASTRA MONOLOCK
 PLATE
 PLATINE
 PLATTE
 PLETINA

Q.TY n.1

6



DADO A.B. M6
 BOLT M6
 ECROU M6
 MUTTER M6
 TUERCA M6

Q.TY n.4

7



COPRIFORO Z621
 BOLT CAP
 CACHE TROU
 STOPLOCK
 TAPA AGUJERO

Q.TY n.6

8



VITE TCEI M6x35
 SCREW M6x35mm
 VIS M6x35mm
 SCHRAUBEM6x35mm
 TORNILLO M6x35mm

Q.TY n.4

9

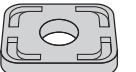

GOMMINO Z1822
 RUBBER
 CAOUTCHOUC
 GUMMI
 GOMA

Q.TY n.4

10



DISTANZIALE Ø11x11mm
 Foro Ø6,5mm, V687
 SPACER
 ENTRETÔISE
 DISTANZSTÜCK
 DISTANCIADOR

Q.TY n.4

11



RONDELLA Z1823
 WASHER
 RONDELLE
 SCHEIBE
 ARANDELA

Q.TY n.4

12



RONDELLA Ø6x20mm
 WASHER Ø6x20mm
 RONDELLE Ø6x20mm
 SCHEIBE Ø6x20mm
 ARANDELA Ø6x20mm

Q.TY n.4

13



RONDELLA Ø6mm
 WASHER Ø6mm
 RONDELLE Ø6mm
 SCHEIBE Ø6mm
 ARANDELA Ø6mm

Q.TY n.4

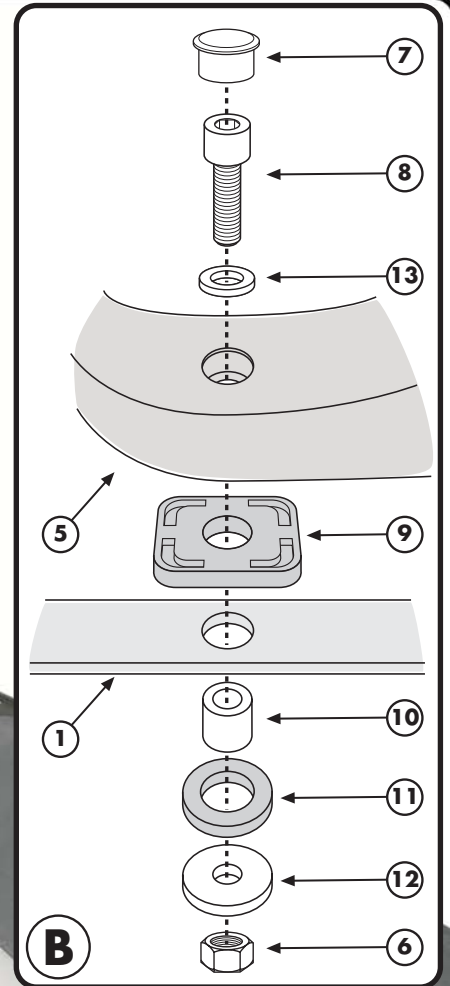
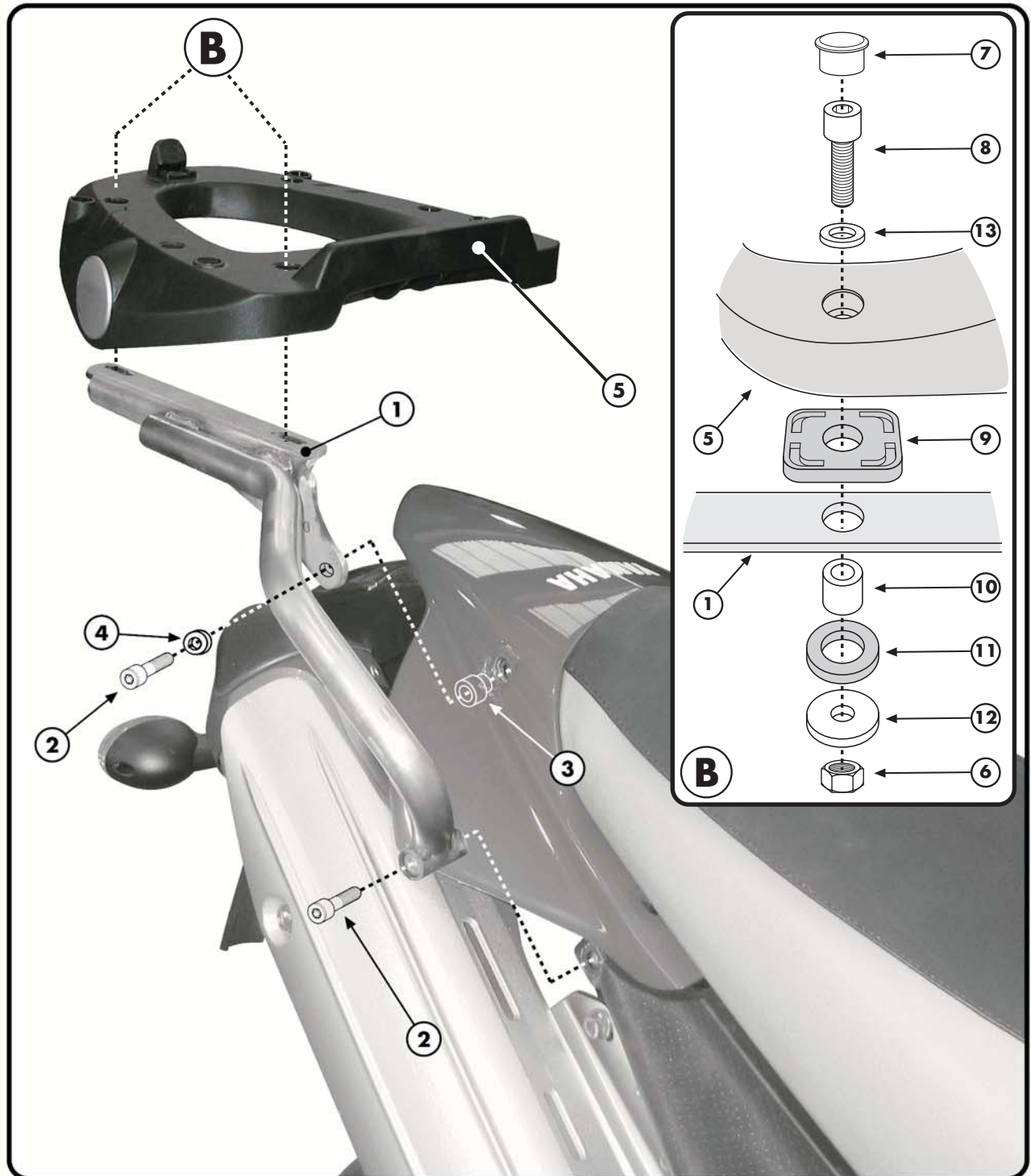

SR353M-KR353M

PORTAVALIGIA SPECIFICO - SPECIFIC CASE HOLDER
PORTE-VALISE SPÉCIFIQUE - SPEZIFISCHER KOFFER-TRÄGER
PORTA-EQUIPAJE ESPECÍFICO

YAMAHA XT660R '04-'06
YAMAHA XT660X '04-'06

ISTRUZIONI DI MONTAGGIO - MOUNTING INSTRUCTIONS
INSTRUCTIONS DE MONTAGE - BAUANLEITUNG - INSTRUCCIONES DE MONTAJE

I ISTRUZIONI DI MONTAGGIO

1. SMONTARE I MANIGLIONI ORIGINALI;
2. POSIZIONARE E MONTARE I SUPPORTI N°1 COME INDICATO IN FOTOGRAFIA;
3. MONTARE LA PIASTRA (PARTICOLARE N° 5) COME INDICATO IN FOTOGRAFIA B;
4. ULTIMARE IL MONTAGGIO CONTROLLANDO CHE TUTTE LE VITI SIANO SERRATE BENE.

GB MOUNTING INSTRUCTIONS

1. REMOVE THE ORIGINAL GRAB RAILS;
2. PLACE AND MOUNT THE SUPPORT N° 1 AS SHOWN IN THE PICTURE;
3. MOUNT THE PLATE (PART N° 5) AS SHOWN IN THE PICTURE B;
4. LASTLY TIGHTEN ALL THE SCREWS.

F INSTRUCTIONS DE MONTAGE

1. DEMONTER LES POIGNEES D'ORIGINE;
2. POSITIONNER ET MONTER LES SUPPORTS N°1 COMME INDIQUE SUR LA PHOTO;
3. MONTER LA PLATINE (PIECE N° 5) COMME INDIQUE SUR LA PHOTO B;
4. TERMINER LE MONTAGE EN CONTROLANT LE BON SERRAGE DE TOUTES LES VIS.

D BAUANLEITUNG

1. ENTFERNEN SIE DIE ORIGINALHANDGRIFFE;
2. POSITIONIEREN UND MONTIEREN SIE DIE HALTERUNGEN NR. 1 WIE IN DEM BILD BESCHRIEBEN;
3. MONTIEREN SIE DIE PLATTE (TEIL NR. 5) WIE IM BILD BESCHRIEBEN B;
4. ZULETZT ZIEHEN SIE ALLE SCHRAUBEN FEST.

ES

INSTRUCCIONES DE MONTAJE

1. DESMONTAR LAS ASAS ORIGINALES;
2. MONTAR LOS SOPORTES N° 1 COMO INDICA LA FOTO;
3. MONTAR LA PARRILLA (DETALLE N° 5) COMO INDICA LA FOTO B;
4. PARA TERMINAR APRETAR TODOS LOS TORNILLOS.