

PORTAVALIGIA SPECIFICO - SPECIFIC CASE HOLDER  
 PORTE-VALISE SPÉCIFIQUE - SPEZIFISCHER KOFFER-TRÄGER  
 PORTA-EQUIPAJE ESPECÍFICO

**SYM JOYMAX 2009**  
**300cc**

ISTRUZIONI DI MONTAGGIO - MOUNTING INSTRUCTIONS  
 INSTRUCTIONS DE MONTAGE - BAUANLEITUNG - INSTRUCCIONES DE MONTAJE



A

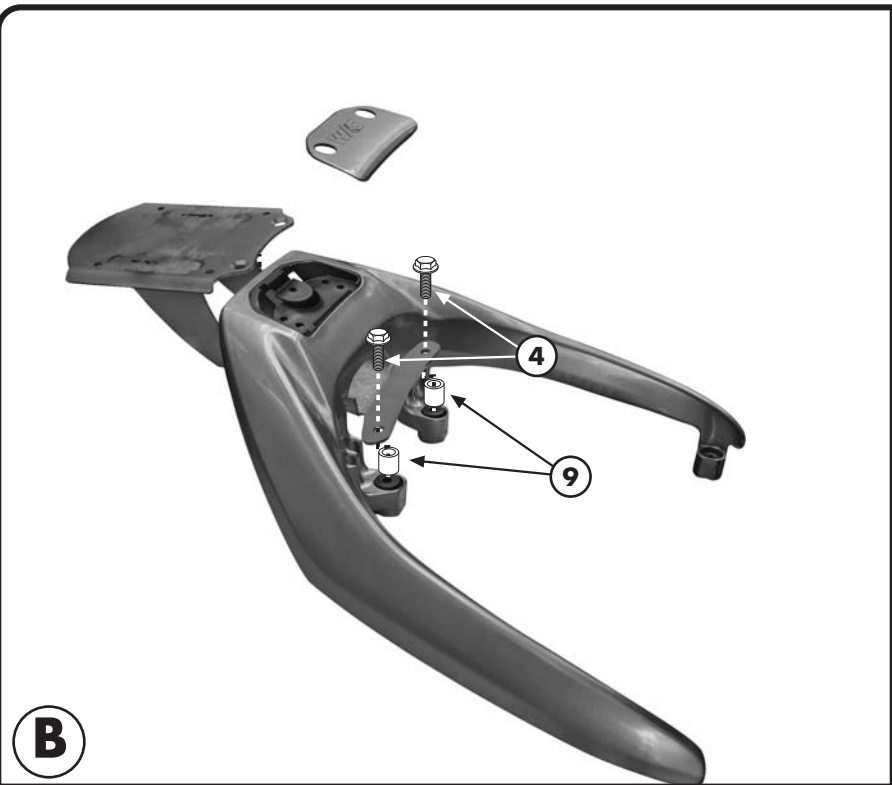

B

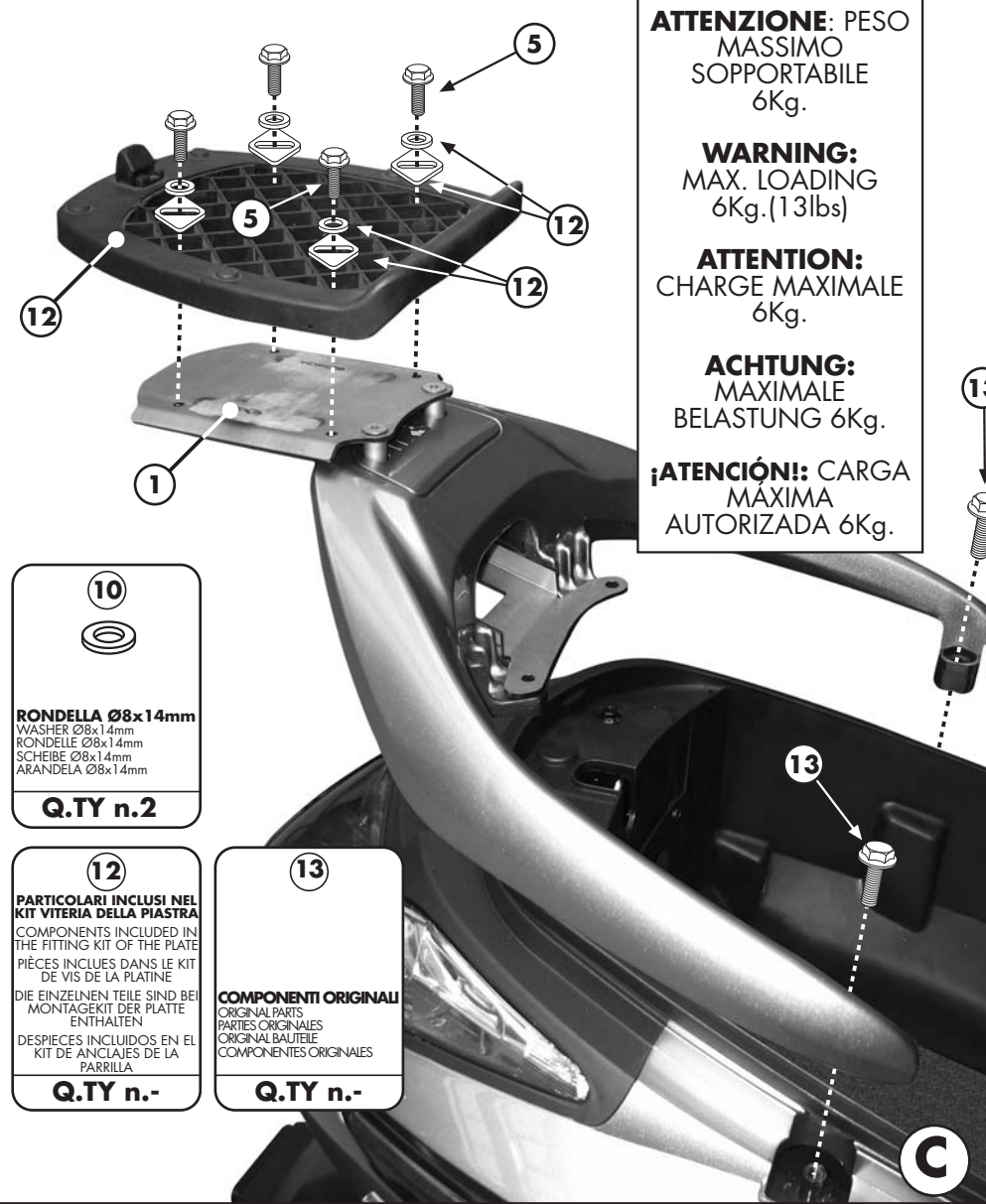
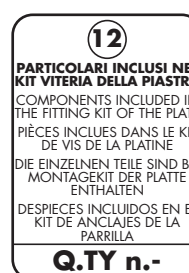
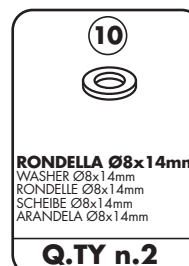
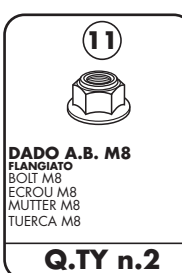
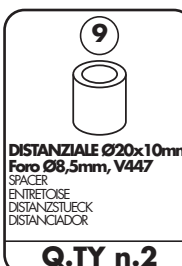
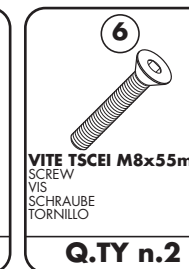
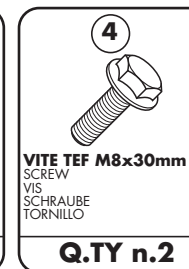
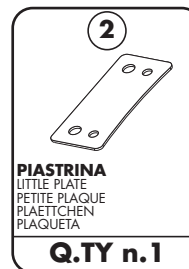

C

**ATTENZIONE: PESO MASSIMO SOPPORTABILE 6Kg.**

**WARNING: MAX. LOADING 6Kg. (13lbs)**

**ATTENTION: CHARGE MAXIMALE 6Kg.**

**ACHTUNG: MAXIMALE BELASTUNG 6Kg.**

**¡ATENCIÓN!: CARGA MÁXIMA AUTORIZADA 6Kg.**

PORTAVALIGIA SPECIFICO - SPECIFIC CASE HOLDER  
PORTE-VALISE SPÉCIFIQUE - SPEZIFISCHER KOFFER-TRÄGER  
PORTA-EQUIPAJE ESPECÍFICO

# SYM JOYMAX 2009

## 300cc

ISTRUZIONI DI MONTAGGIO - MOUNTING INSTRUCTIONS  
INSTRUCTIONS DE MONTAGE - BAUANLEITUNG - INSTRUCCIONES DE MONTAJE

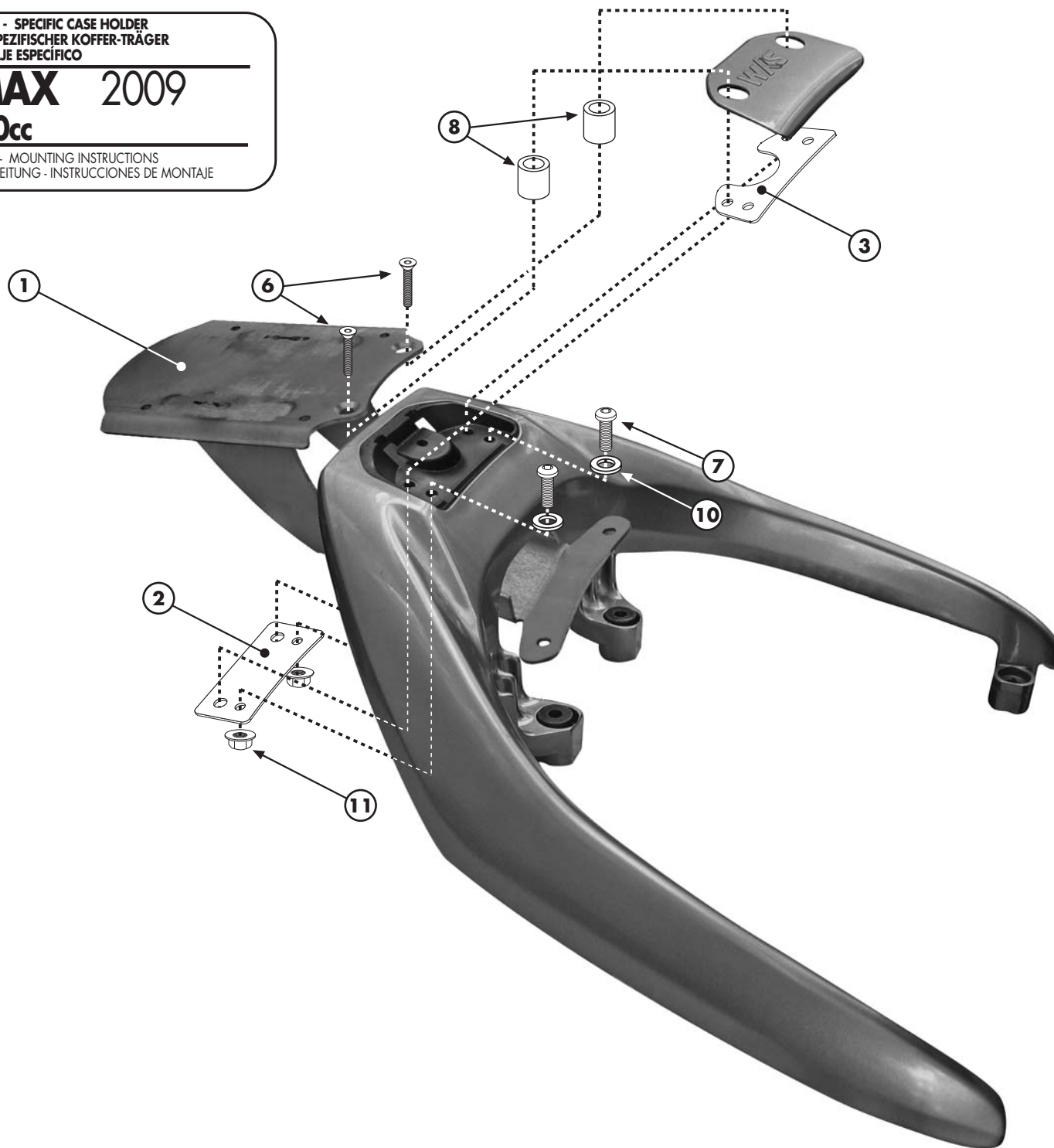

PORTAVALIGIA SPECIFICO - SPECIFIC CASE HOLDER  
 PORTE-VALISE SPECIFIQUE - SPEZIFISCHER KOFFER-TRÄGER  
 PORTA-EQUIPAJE ESPECIFICO

**SYM JOYMAX 2009**  
**300cc**

ISTRUZIONI DI MONTAGGIO - MOUNTING INSTRUCTIONS  
 INSTRUCTIONS DE MONTAGE - BAUANLEITUNG - INSTRUCCIONES DE MONTAJE

## I ISTRUZIONI DI MONTAGGIO

1. SMONTARE IL CARTERINO ORIGINALE SITUATO SOTTO AL MANIGLIONE;
2. MONTARE IL SUPPORTO N° 1 AL MANIGLIONE ORIGINALE COME INDICATO IN FIGURA B;
3. RIMONTARE IL MANIGLIONE ALLO SCOOTER COME MOSTRATO IN FIGURA C.
4. ULTIMARE IL MONTAGGIO VERIFICANDO CHE TUTTE LE VITI SIANO SERRATE BENE (VITI M6=9,6Nm - VITI M8=23Nm).

## GB MOUNTING INSTRUCTIONS

1. DISASSEMBLE THE SMALL ORIGINAL PLASTIC YOU SEE UNDER THE GRAB-HANDLE;
2. SET THE SUPPORT N°1 TO THE ORIGINAL GRAB-HANDLE AS YOU CAN SEE FROM PICTURE B;
3. SET AGAIN THE HANDLE TO THE SCOOTER AS YOU CAN SEE FROM PICTURE C;
4. CHECK THAT ALL THE SCREWS ARE WELL TIGHTENED (SCREWS M6=9,6Nm - SCREWS M8=23Nm).

## F INSTRUCTIONS DE MONTAGE

1. DEMONTER LE PETIT CARTER ORIGINAL SITUE AU DESSOUS DE LA POIGNEE;
2. MONTER LE SUPPORT N°1 A LA POIGNEE D'ORIGINE COMME INDIQUE EN PHOTO B;
3. REMONTER LA POIGNEE AU SCOOTER COMME ILLUSTRE EN PHOTO C;
4. TERMINER LE MONTAGE EN CONTROLANT LE BON SERRAGE DE TOUTES LES VIS (VIS M6=9,6Nm - VIS M8=23Nm).

## D BAUANLEITUNG

1. DEMONTIEREN SIE DIE HECKVERKLEIDUNG, DIE UNTERHALB DES HANDGRIFFS IST;
2. MONTIEREN SIE DIE HALTERUNG NR. 1 AN DEM ORIGINAL HANDGRIFF WIE IM BILD B GEZEIGT;
3. MONTIEREN SIE DEN HANDGRIFF AUF DEM ROLLER WIE IM BILD C GEZEIGT;
4. ZULETZT ÜBERPRÜFEN SIE DAS ALLE SCHRAUBEN (SCHRAUBEN M6=9,6NM - SCHRAUBEN M8=23NM) FESTGEZOGEN WURDEN.

## ES INSTRUCCIONES DE MONTAJE

1. DESMONTAR EL PEQUEÑO COLÍN ORIGINAL QUE ESTÁ BAJO EL ASIDERO FOTO A;
2. MONTAR EL SOPORTE N. 1 AL ASIDERO ORIGINAL COMO SE INDICA EN LA FOTO B;
3. VOLVER A MONTAR EL ASIDERO AL SCOOTER COMO SE INDICA EN LA FOTO C;
4. TERMINAR EL MONTAJE VERIFICANDO QUE TODOS LOS TORNILLOS ESTÉN BIEN APRETADOS ((TORNILLOS M6=9,6NM - TORNILLOS M8=23NM).