

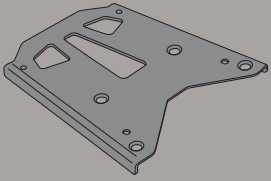

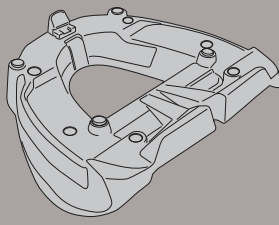



SR1123MM - KR1123MM

PORTAPACCO SPECIFICO - SPECIFIC HOLDER - PORTE-PAQUET SPÉCIFIQUE - SPEZIFISCHER TRÄGER - PORTA-EQUIPAJE ESPECÍFICO - TRANSPORTADOR ESPECÍFICO

HONDA FORZA 300 ABS (2013)

N°	Descrizione	Caratteristiche	Codice	Quantità	
1	Supporto - Support - Support Halteung - Soporte - Apoio	Sp. 3mm	GL2466	1	
2	Piastra - Plate Platine - Platte Parrilla - Prato	-	M6M	1	
3	Distanziale - Spacer Entretoise - Distanzstueck Distanciador - Espaçador	Ø18x45 Foro 10mm	C18L45F10T	4	
4	Vite - Screw Vis - Schraube Tornillo - Parafuso	TSCEI M8x65	865TSP	4	
5	Vite - Screw Vis - Schraube Tornillo - Parafuso	TCEI M6x25	625TCE	4	
6	Dado - Bolt - Ecrou Mutter - Tuerca - Porca	Auto Bloccante Flangiato M6	6DADIAFLN	4	
7	Rondella - Washer Rondelle - Scheibe Arandela - Arruela	Ø6	6RON	4	
8	Copriforo - Bolt Cap Cache Trou - Stopslock Tapa Agujero - Tampa do Orifício	-	Z621	6	

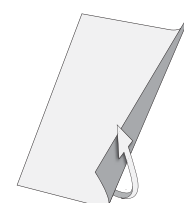

SR1123MM - KR1123MM

PORTAPACCO SPECIFICO - SPECIFIC HOLDER - PORTE-PAQUET SPÉCIFIQUE - SPEZIFISCHER TRÄGER - PORTA-EQUIPAJE ESPECÍFICO - TRANSPORTADOR ESPECÍFICO

HONDA FORZA 300 ABS (2013)

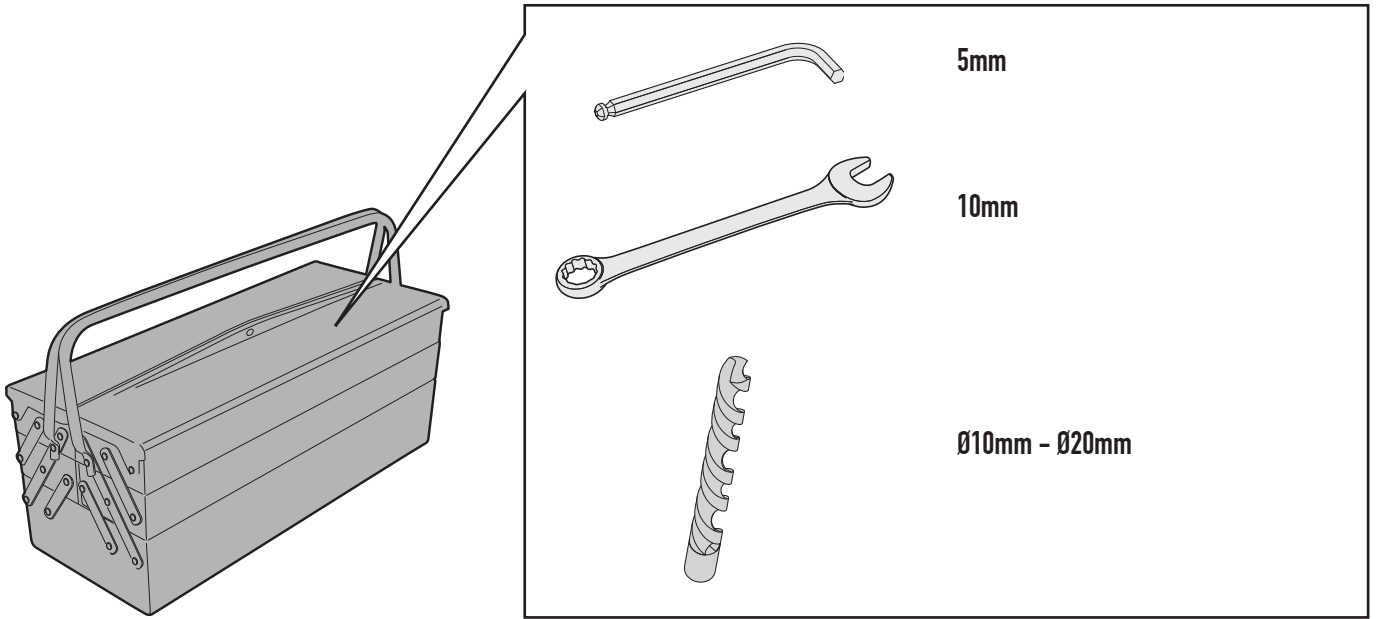

SR1123MM - KR1123MM

PORTAPACCO SPECIFICO - SPECIFIC HOLDER - PORTE-PAQUET SPÉCIFIQUE - SPEZIFISCHER TRÄGER - PORTA-EQUIPAJE ESPECÍFICO - TRANSPORTADOR ESPECÍFICO

HONDA FORZA 300 ABS (2013)

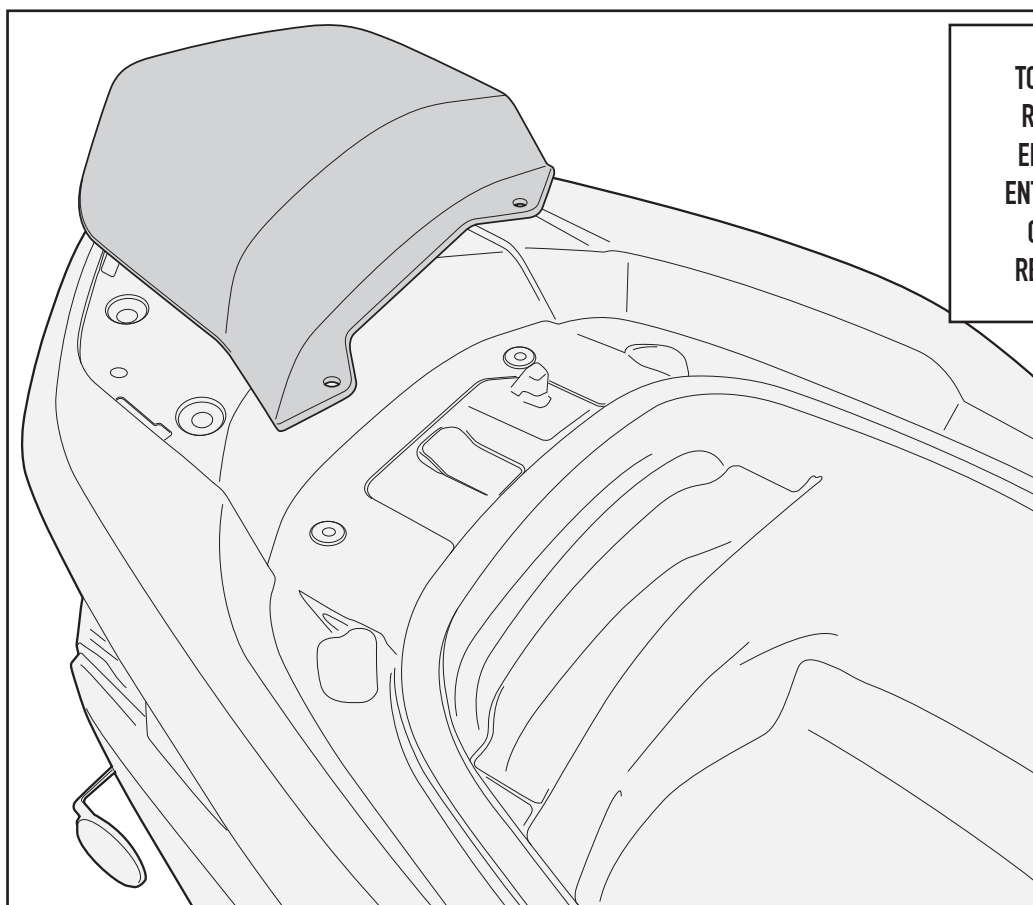

TOGLIERE
REMOVE
ENLEVER
ENTFERNEN
QUITAR
REMOVED

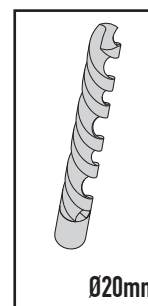
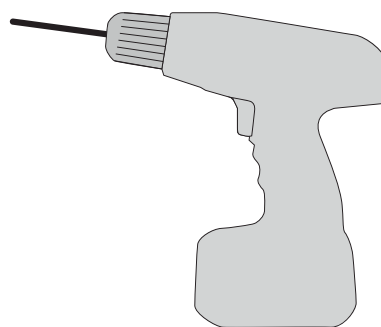
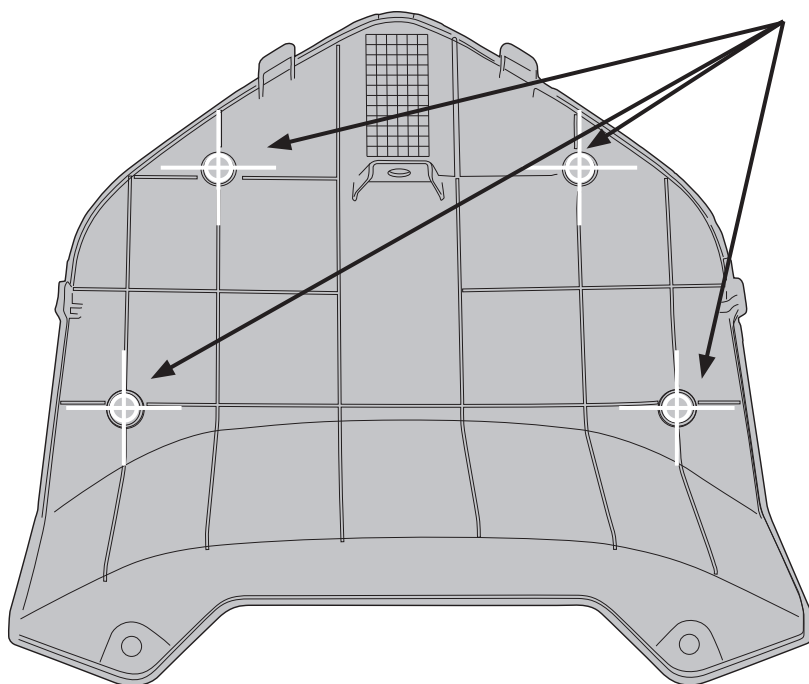

- . Forare nei 4 punti indicati; forare prima con una punta piccola ($\varnothing 10$), poi allargarli con una punta da 20mm.
- . Pierce the 4 points marked; start with a small point ($\varnothing 10$) and check the points are lined up with the original screws below; then enlarge the holes with a $\varnothing 20$ point.
- . Percer les 4 points indiqués en commençant avec un foret 10mm, vérifier qu'ils sont alignés avec les vis originales dessous, puis aggrandir les trous avec un foret de 20mm.
- . Mit einem 10mm Bohrer vorbohren; dann überprüfen ob die Bohrungen mit den Originalschrauben mittig sind; jetzt die Löcher auf 20mm aufbohren.
- . Agujerar en los 4 puntos indicados; agujerar primero con la punta pequeña ($\varnothing 10$ mm), controlar que concidan con los tornillos que se encuentran en el chasis de la moto, luego ampliar el agujero con una punta de 20mm.
- . Agujerar en los 4 puntos indicados; luego el ampliar agujero con un pouco de 20 milímetros.

SR1123MM - KR1123MM

PORTAPACCO SPECIFICO - SPECIFIC HOLDER - PORTE-PAQUET SPECIFIQUE - SPEZIFISCHER TRÄGER - PORTA-EQUIPAJE ESPECÍFICO - TRANSPORTADOR ESPECÍFICO

HONDA FORZA 300 ABS (2013)

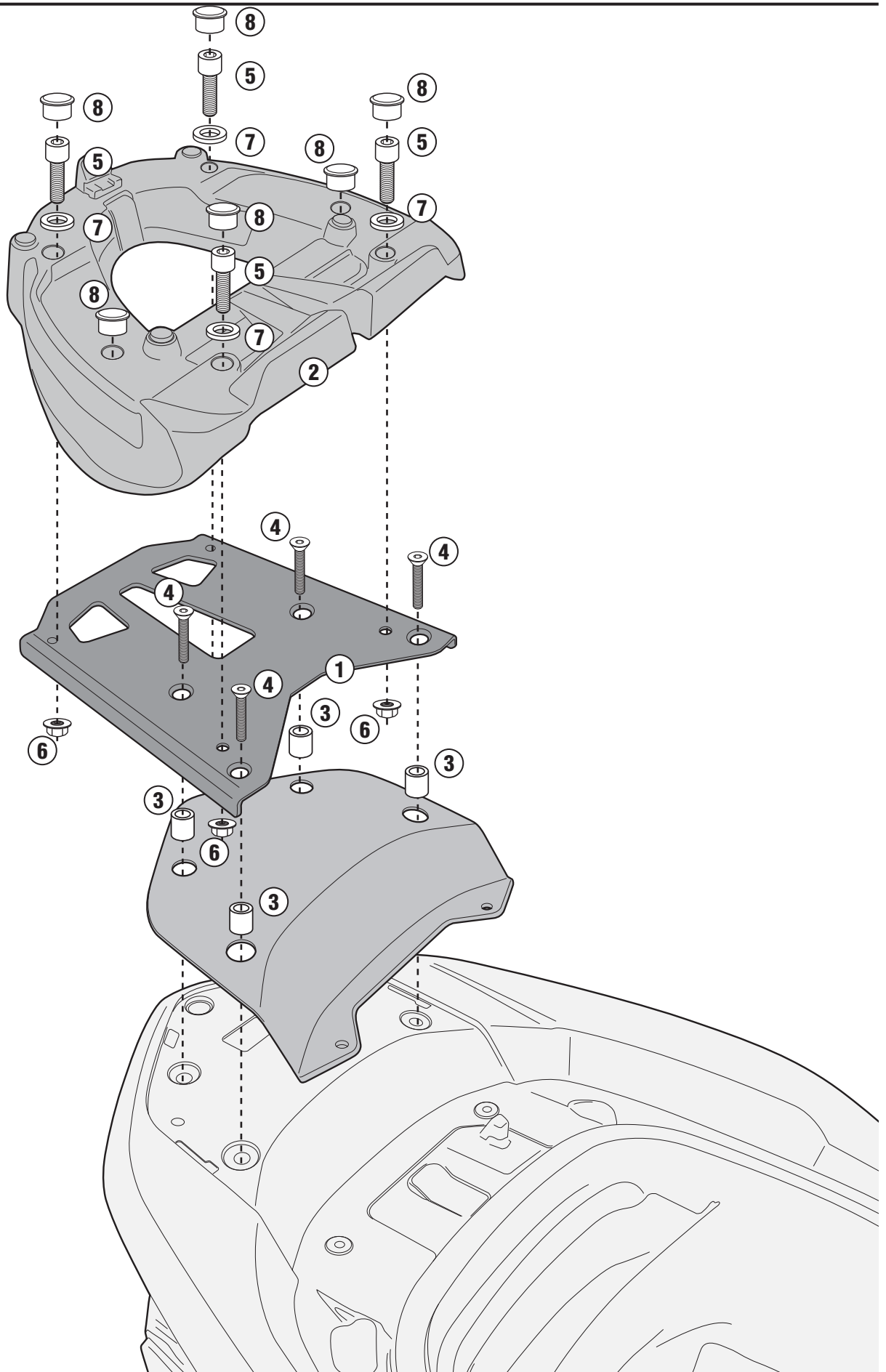

ISTRUZIONI DI MONTAGGIO - MOUNTING INSTRUCTIONS
INSTRUCTIONS DE MONTAGE - BAUANLEITUNG
INSTRUCCIONES DE MONTAJE - INSTRUÇÕES DE MONTAGEM