



PARAMOTORE SPECIFICO - SPECIFIC ENGINE GUARD - PARE-CARTER SPECIFIQUE
 SPEZIFISCHER STURZBÜGEL - DEFENSA DE MOTOR ESPECÍFICA

KAWASAKI KLR 650 2008

ISTRUZIONI DI MONTAGGIO - MOUNTING INSTRUCTIONS
 INSTRUCTIONS DE MONTAGE - BAUANLEITUNG - INSTRUCCIONES DE MONTAJE

1

VITE TEF M6x20mm
 SCREW
 VIS
 SCHRAUBE
 TORNILLO
Q.TY n.2

2

DADO A.B. M6
 FLANGIATO
 BOLT M6
 ECRU M6
 MUTTER M6
 TUERCA M6
Q.TY n.2

3
COMPONENTI ORIGINALI
 ORIGINAL PARTS
 PARTIES ORIGINALES
 ORIGINAL BAUTEILE
 COMPONENTES ORIGINALES
Q.TY n.6

4

VITE TCEI M8x20mm
 SCREW
 VIS
 SCHRAUBE
 TORNILLO
Q.TY n.2

5

RONDELLA Ø8x32mm
 WASHER Ø8x32mm
 RONDELLE Ø8x32mm
 SCHEIBE Ø8x32mm
 ARANDELA Ø8x32mm
Q.TY n.2

6
NIPPLES 347TN
Q.TY n.1

7

PONTE
 BRIDGE
 PONT
 BRÜCKE
 PUENTE
Q.TY n.1

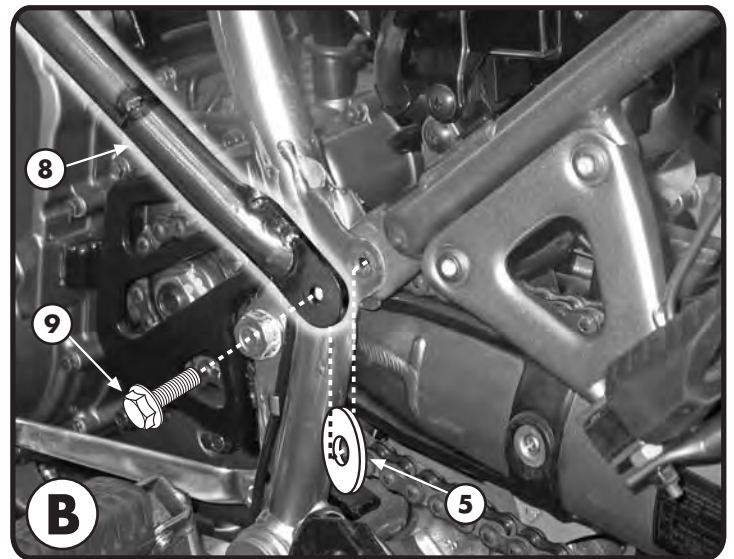
8
PARAMOTORE
 ENGINE GUARD
 PARE-CARTER
 STURZBUEGEL
 DEFENSA DE MOTO
Q.TY n.2(dx-sx)

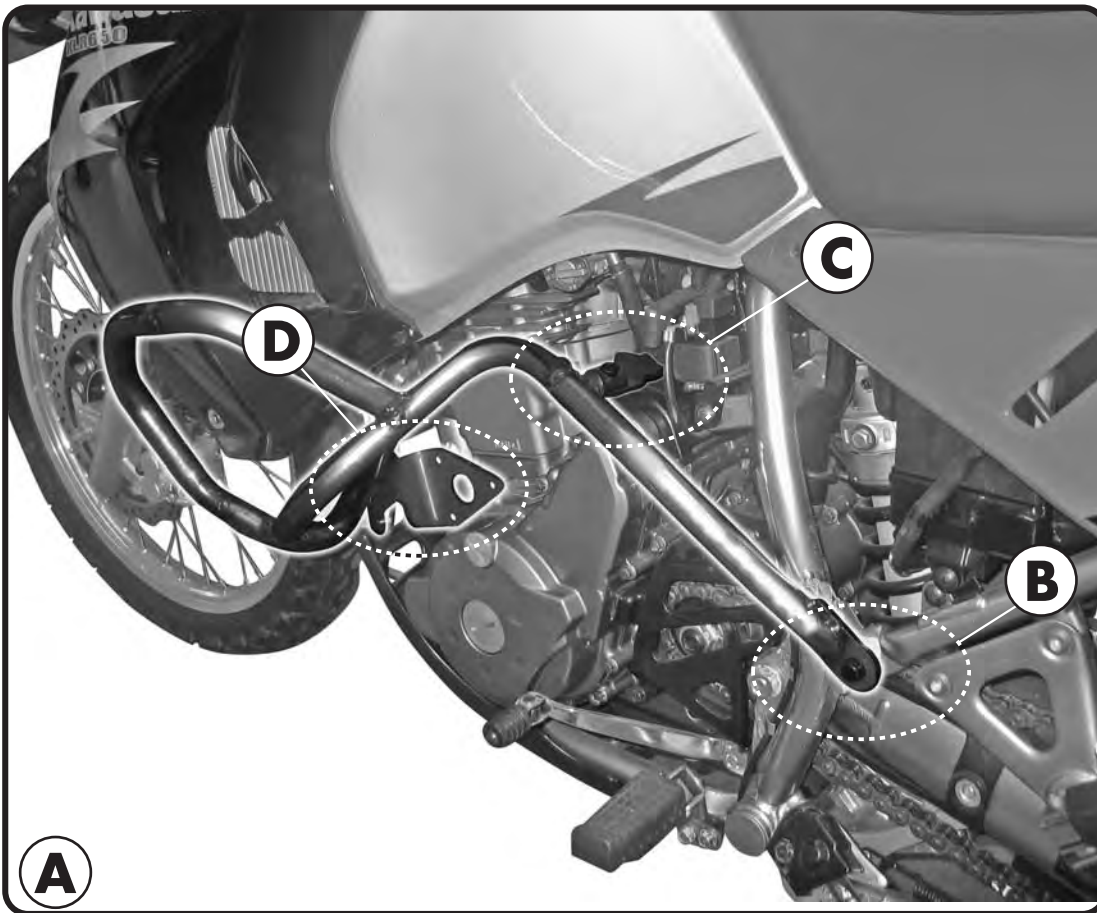
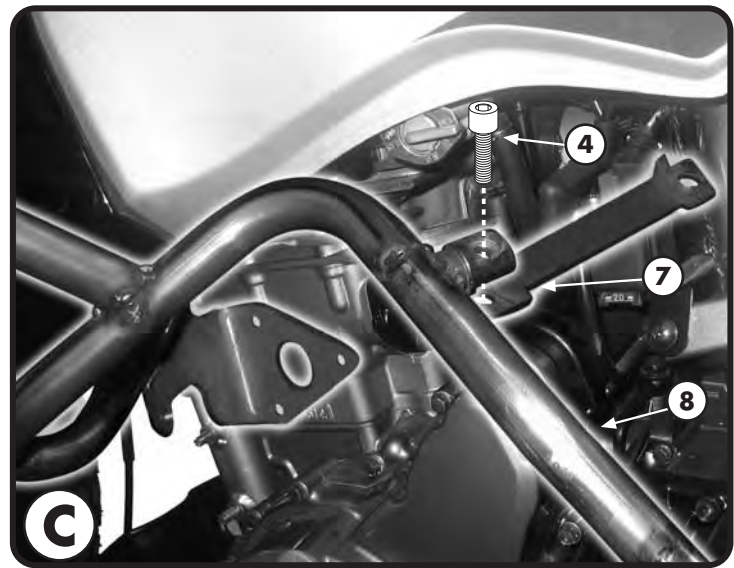

9

VITE TEF M8x35mm
 SCREW
 VIS
 SCHRAUBE
 TORNILLO
Q.TY n.2



PARAMOTORE SPECIFICO - SPECIFIC ENGINE GUARD - PARE-CARTER SPECIFIQUE
 SPEZIFISCHER STURZBÜGEL - DEFENSA DE MOTOR ESPECÍFICA

KAWASAKI KLR 650 2008

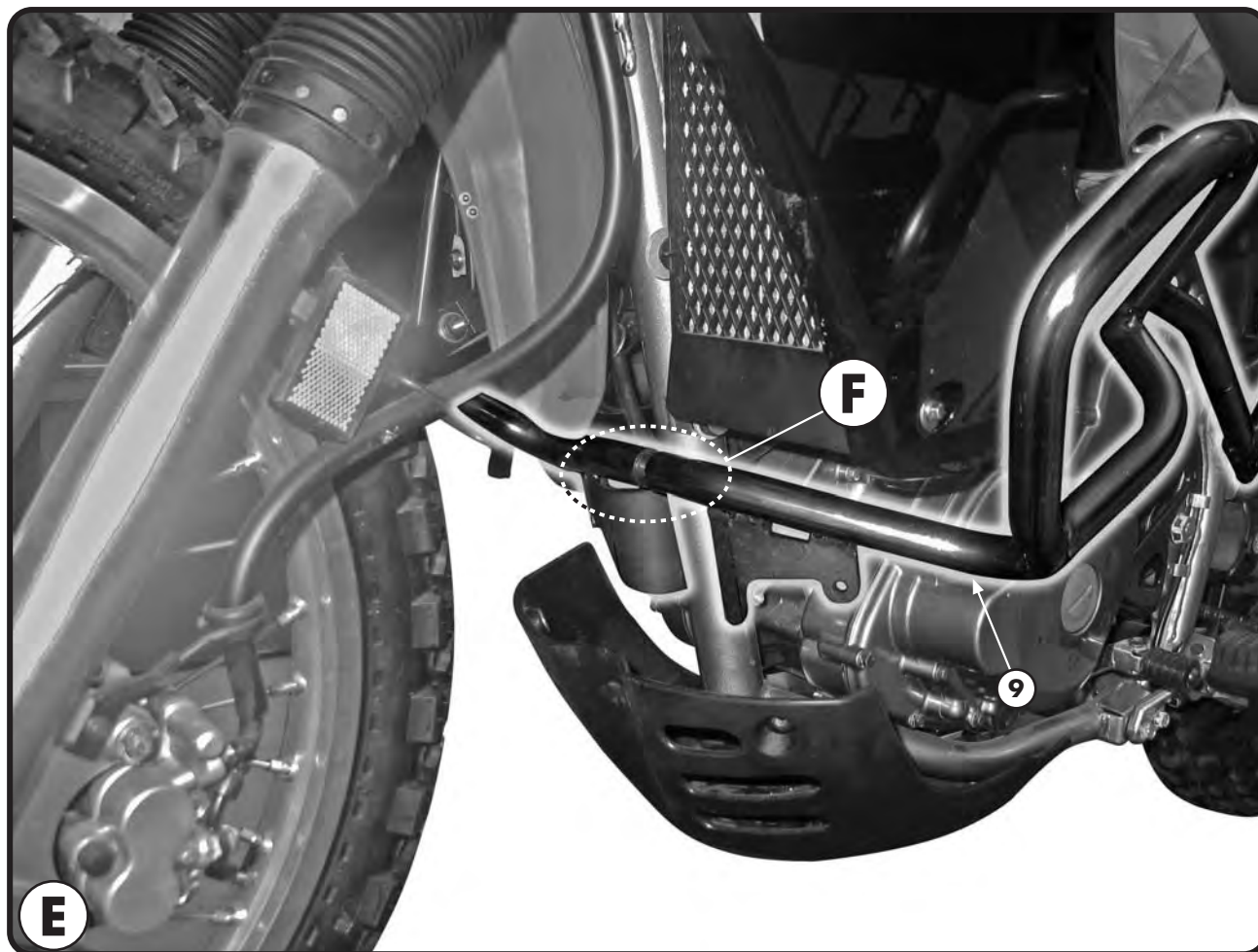
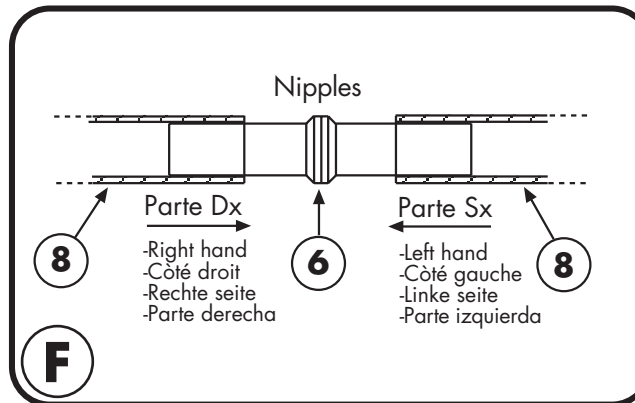
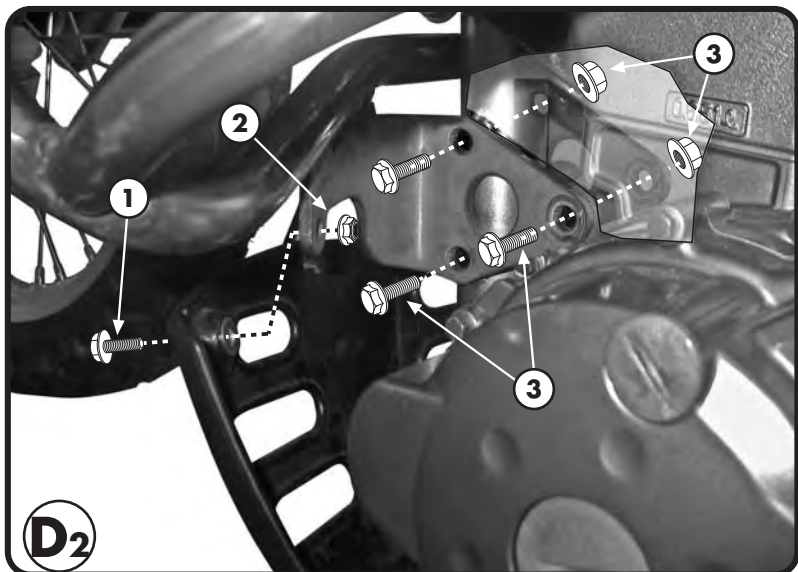
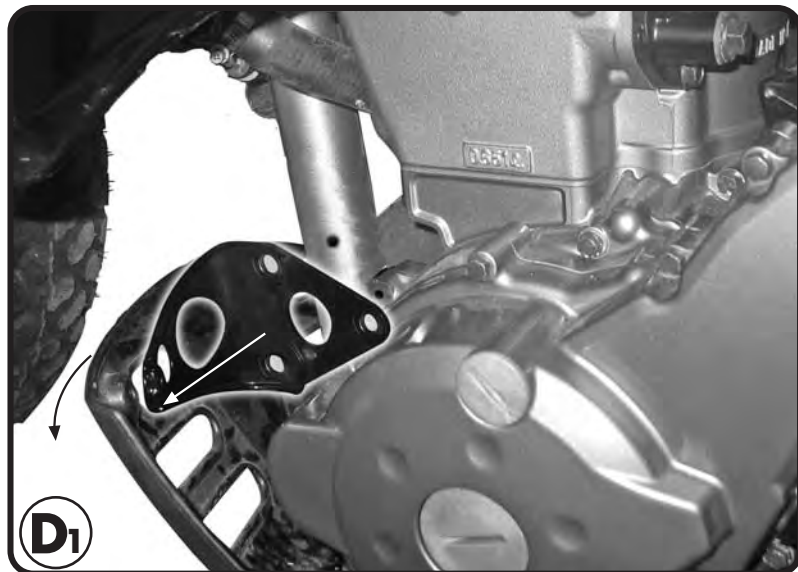
ISTRUZIONI DI MONTAGGIO - MOUNTING INSTRUCTIONS
 INSTRUCTIONS DE MONTAGE - BAUANLEITUNG - INSTRUCCIONES DE MONTAJE



PARAMOTORE SPECIFICO - SPECIFIC ENGINE GUARD - PARE-CARTER SPECIFIQUE
 SPEZIFISCHER STURZBÜGEL - DEFENSA DE MOTOR ESPECIFICA

KAWASAKI KLR 650 2008

ISTRUZIONI DI MONTAGGIO - MOUNTING INSTRUCTIONS
 INSTRUCTIONS DE MONTAGE - BAUANLEITUNG - INSTRUCCIONES DE MONTAJE

I ISTRUZIONI DI MONTAGGIO

1. IN FIGURA A E' RIPORTATO IL RISULTATO FINALE DEL MONTAGGIO DEL PARAMOTORE;
2. SEGUIRE IL MOTNAGGIO DELLE FIGURE B e C, FACENDO PARTICOLARE ATTENZIONE AL COLLOCAMENTO DEL PONTE (PARTICOLARE N° 7 FIGURA C);
3. RIMUOVERE TEMPORANEAMENTE IL PARACOPPA E TOGLIERE I SUPPORTI ORIGINALI COME INDICATO IN FIGURA D1
4. PROCEDERE AL FISSAGGIO DEL PARAMOTORE COME INDICATO IN FIGURA D2, PRESTANDO PARTICOLARE ATTENZIONE ALL'INSERIMENTO DEL NIPPLES (PARTICOLARE 4 FIGURA F).

GB MOUNTING INSTRUCTIONS

1. PICTURE A SHOWS THE ENGINE GUARD POSITIONING AFTER INSTALLATION;
2. FOLLOW THE INSTALLATION PROCESS SHOWN IN PICTURE B AND C, PAYING SPECIAL ATTENTION TO THE POSITION OF THE BRIDGE (DETAIL N°7 IN PICTURE C);
3. TEMPORARILY REMOVE THE SKID PLATE AND TAKE OUT THE ORIGINAL SUPPORTS AS SHOWN IN PICTURE D1; 4.
4. CONTINUE WITH THE INSTALLATION OF THE ENGINE GUARD AS SHOWN IN PICTURE D2, PAYING SPECIAL ATTENTION TO THE INSERTION AND INSTALLATION OF THE JUNCTION SLEEVE (DETAIL 4 IN PICTURE F).

F INSTRUCTIONS DE MONTAGE

1. EN PHOTO A EST ILLUSTRE LE RESULTAT FINAL DU MONTAGE DU PARE-CARTER;
2. SUIVRE LE MONTAGE DES PHOTOS B ET C, EN FAISANT TRES ATTENTION AU POSITIONNEMENT DU PONT (PIECE N°7 PHOTO C);
3. REPOUSSER TEMPORAIREMENT LE SABOT ET ENLEVER LES SUPPORTS D'ORIGINE COMME INDIQUE EN PHOTO D1;
4. PROCEDER A LA FIXATION DU PARE-CARTER COMME INDIQUE EN PHOTO D2, EN FAISANT PARTICULIEREMENT ATTENTION A L'INSERTION DES MANCHONS (PIECE N° 4 PHOTO F).

D BAUANLEITUNG

1. IN BILD A KÖNNEN SIE DAS ENDRESULTAT DER MONTAGE SEHEN;
2. FOLGEN SIE DER MONTAGE DER BILDER B UND C UND BEACHTEN SIE BITTE DIE POSITIONIERUNG DER BRÜCKE (POSITION NR. 7 BILD C);
3. ENTFERNEN SIE VORÜBERGEHEND DEN WANNESCHUTZ UND NEHMEN SIE DIE ORIGINAL HALTERUNGEN WEG WIE IM BILD D1 GEZEIGT;
4. BEFESTIGEN SIE DEN STURZBÜGEL WIE IM BILD D2 GEZEIGT UND BEACHTEN SIE BESONDERS DAS EINSTECKEN DER GUMMIS (POSITION NR. 4 BILD F).

ES INSTRUCCIONES DE MONTAJE

1. EN LA FOTO "A" FIGURA EL RESULTADO FINAL DEL MONTAJE DE LA DEFENSA (DE MOTOR)
2. SEGUIR EL MONTAJE DE LAS ILUSTRACIONES "B" Y "C", CON PARTICULAR ATENCIÓN A LA POSICIÓN DEL PUENTE (REFERENCIA N.7, FOTO "C");
3. DESMONTAR TEMPORALMENTE EL CUBRECARTER Y QUITAR LOS SOPORTES ORIGINALES COMO SE INDICA EN LA FOTO "D1"
4. PROCEDER FIJANDO LA DEFENSA (DE MOTOR) COMO FIGURA EN LA FOTO "D2", HACIENDO PARTICULAR ATENCIÓN A LA INSERCIÓN DE LAS UNIONES (REFERENCIA N. 4 ILUSTRADO EN LA FOTO "F")

