

PORTAVALIGIE LATERALE SPECIFICO - SPECIFIC TUBULAR SIDE-CASE HOLDER
 PORTE-VALISES LATÉRAUX SPÉCIFIQUE - SPEZIFISCHES STAHLROHR-SEITENTRÄGER
 PORTA MALETAS LATERALES ESPECÍFICO

BMW K1300R

2009

ISTRUZIONI DI MONTAGGIO - MOUNTING INSTRUCTIONS
 INSTRUCTIONS DE MONTAGE - BAUANLEITUNG - INSTRUCCIONES DE MONTAJE

1



SUPPORTO
 SUPPORT
 SUPPORT
 HALTERUNG
 SOPORTE

Q.TY n.2(Dx-5x)

2



SUPPORTO
 SUPPORT
 SUPPORT
 HALTERUNG
 SOPORTE

Q.TY n.2(Dx-5x)

3



SUPPORTO
 SUPPORT
 SUPPORT
 HALTERUNG
 SOPORTE

Q.TY n.2(Dx-5x)

4



PONTE POSTERIORE
 REAR BRIDGE
 PONT POSTÉRIEURE
 VERBUNDUNGSROHR
 PUENTE TRASERO

Q.TY n.1

5



SUPPORTO
 SUPPORT
 SUPPORT
 HALTERUNG
 SOPORTE

Q.TY n.1

6



VITE TBEI M8x16mm
 SCREW
 VIS
 SCHRAUBE
 TORNILLO

Q.TY n.2

7



VITE TCEI M8x45mm
 SCREW
 VIS
 SCHRAUBE
 TORNILLO

Q.TY n.4

8



VITE TEF M6x20mm
 SCREW
 VIS
 SCHRAUBE
 TORNILLO

Q.TY n.2

9



RONDELLA Ø8x14mm
 WASHER
 RONDELLE Ø8x14mm
 SCHEIBE Ø8x14mm
 ARANDELA Ø8x14mm

Q.TY n.6

10



DISTANZIALE Ø14x7mm
 Foro Ø 6mm, V134
 SPACER
 ENTRETOISE
 DISTANZSTÜCK
 DISTANCIADOR

Q.TY n.2

11



DISTANZIALE Ø14x15mm
 Foro Ø8,5mm, V750
 SPACER
 ENTRETOISE
 DISTANZSTÜCK
 DISTANCIADOR

Q.TY n.2

12

COMPONENTI ORIGINALI
 ORIGINAL PARTS
 PARTIES ORIGINALES
 ORIGINAL BAUTEILE
 COMPONENTES ORIGINALES

Q.TY n.-

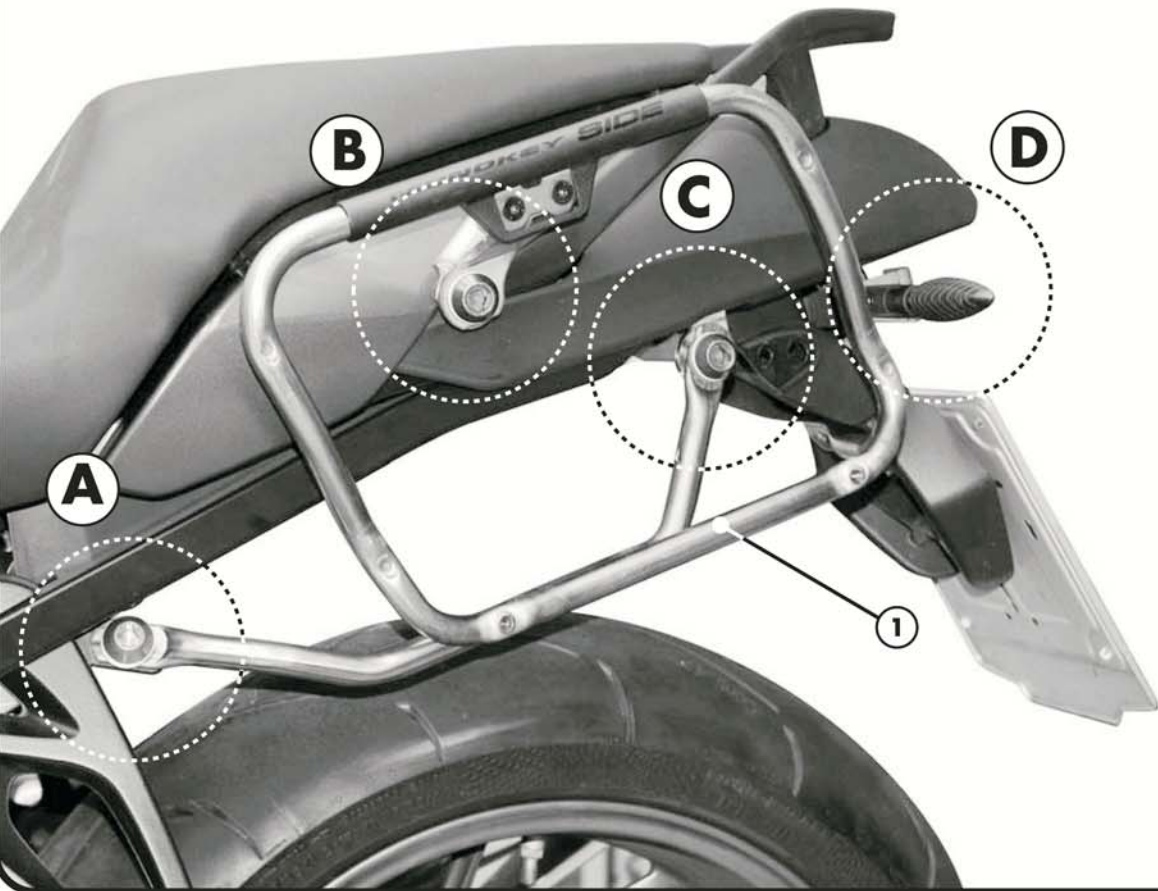
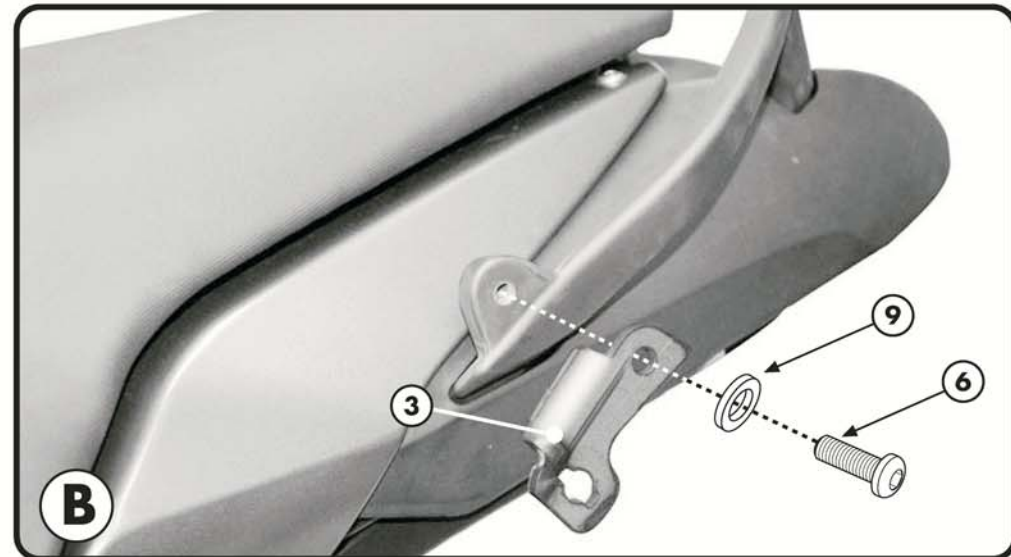
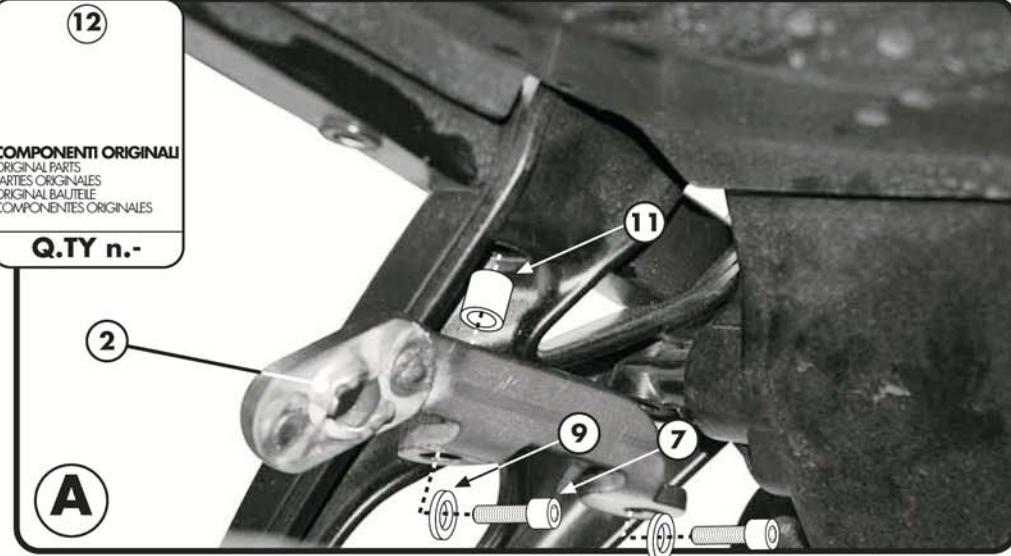

PORTAVALIGIE LATERALE SPECIFICO - SPECIFIC TUBULAR SIDE-CASE HOLDER
 PORTE-VALISES LATÉRAUX SPÉCIFIQUE - SPEZIFISCHES STAHLROHR-SEITENTRAEGER
 PORTA MALETAS LATERALES ESPECIFICO

BMW K1300R

2009

ISTRUZIONI DI MONTAGGIO - MOUNTING INSTRUCTIONS
 INSTRUCTIONS DE MONTAGE - BAUANLEITUNG - INSTRUCCIONES DE MONTAJE

13
PARTICOLARI INCLUSI NEL KIT VITERIA DEL SR
 COMPONENTS INCLUDED IN THE FITTING KIT OF THE SR
 PIÉCES INCLUES DANS LE KIT DE VIS DE EL SR
 DIE EINZELNEN TEILE SIND BEI MONTAGEKIT DER SR ENTHALTEN
 DESPIECES INCLUIDOS EN EL KIT DE ANCLAJES DE EL SR

Q.TY n.-

14

CHIAVE PER VITI A TESTA SPECIALE
 SPECIAL KEY
 CLE SPECIALE
 SPEZIALSCHLÜSSEL ZUR DEMONTAGE DES TRÄGERS
 LLAVE PARA TORNILLOS CON CABEZA ESPECIAL

Q.TY n.1

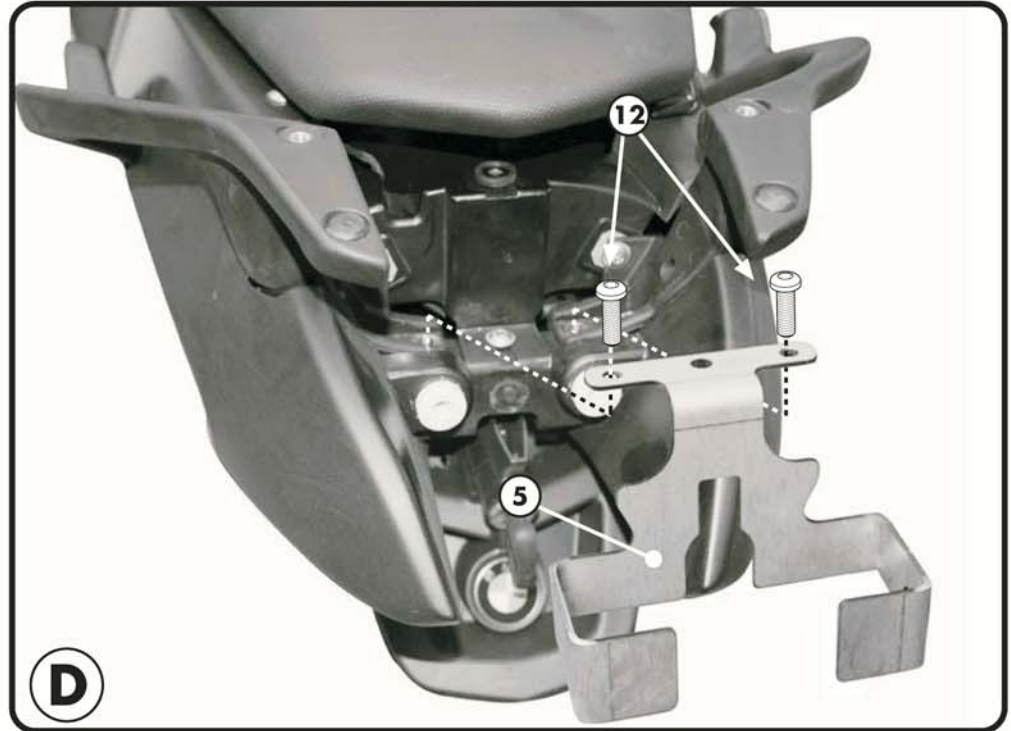
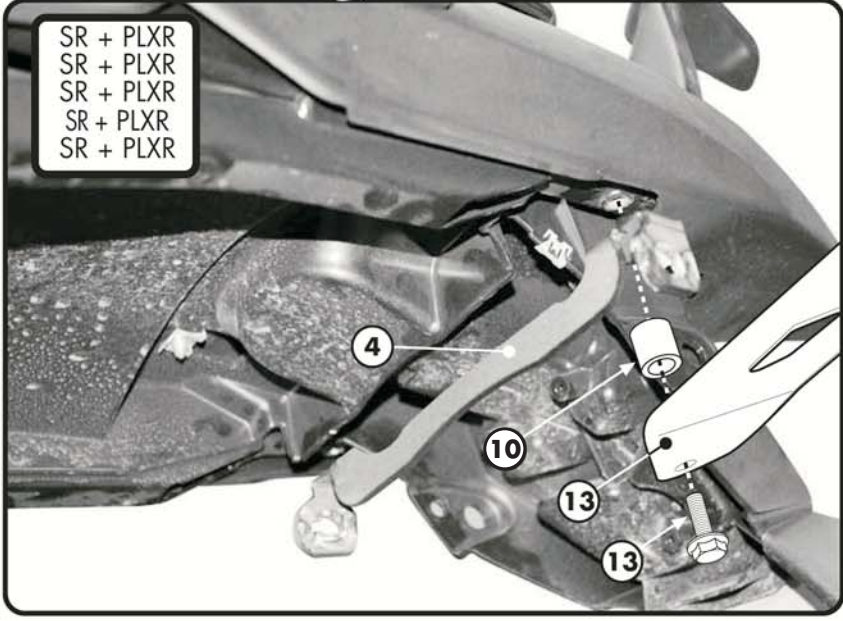
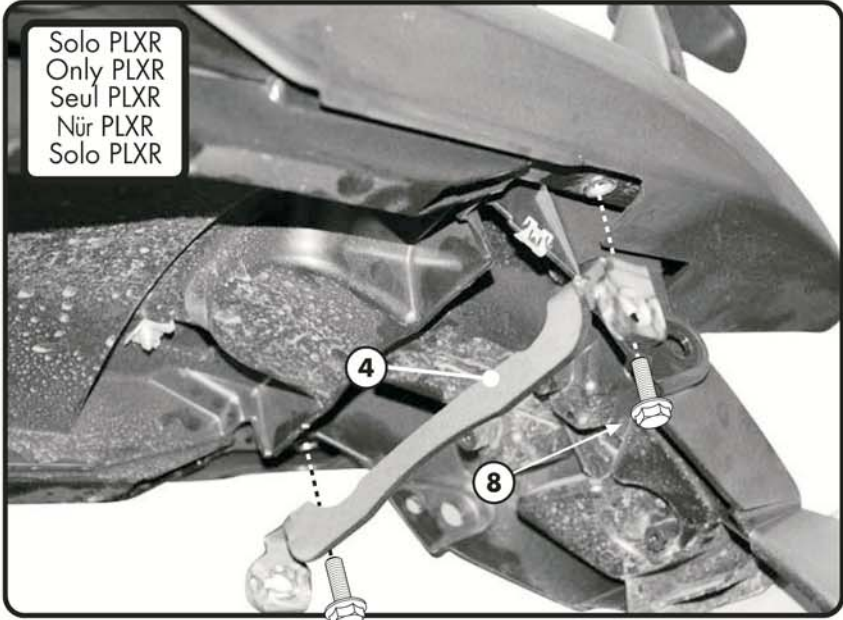

MONTAGGIO / SMONTAGGIO PORTAVALIGE LATERALE VERSIONE PLXR "RAPID"

1



2



I

1. INSERIRE L'ATTREZZO NELLA TESTA DELLA VITE SPECIALE;
2. RUOTARE DI 1/4 DI GIRO IN SENSO ORARIO FINO A CHE LA ROTAZIONE NON TERMINA E SI AVVERTE LO SCATTO;
3. PER SMONTARE PROCEDERE IN SENSO INVERSO.

GB

1. INSERT THE SPECIAL KEY INTO THE HEAD OF THE SCREW;
2. TURN THE KEY ¼ TURN CLOCKWISE UNTIL ROTATION STOPS AND THE SIDE CASE HOLDER IS FASTENED SECURELY TO THE FITMENT POINT;
3. IN ORDER TO DISASSEMBLE THE BRACKETRY PERFORM THE OPERATION IN REVERSE.

F

1. INSERER LA CLE SPECIALE DANS LA TÊTE DE LA VIS;
2. VISSER D'1/4 DE TOUR DANS LE SENS HORAIRE JUSQU'AU BLOCAGE DE LA VIS POUR MONTER EN TOUTE SECURITE LE SUPPORT A SON POINT DE FIXATION;
3. POUR LE DEMONTAGE, PROCEDER EN SENS INVERSE.

D

1. STECKEN SIE DAS WERKZEUG IN DEN KOPF DER SPEZIFISCHEN SCHRAUBE;
2. DREHEN SIE DIE SCHRAUBE 1 / 4 UMDREHUNG IM UHRZEIGERSINN BIS SIE BEMERKEN, DASS DIE SCHRAUBE IM BEFESTIGUNGSPUNKT EINGEKLEMMT IST;
3. FÜR DIE DEMONTAGE FOLGEN SIE DEN HINWEISE UMGEKEHRT.

ES

1. INSERTAR LA LLAVE ESPECIAL EN LA CABEZA DEL TORNILLO
2. DAR ¼ DE VUELTA EN EL SENTIDO HORARIO HASTA QUE LLEGUE AL TOPE Y SE VEA EL TORNILLO;
3. PARA DESMONTARLO PROCEDER EN LA DIRECCIÓN CONTRARIA;

3

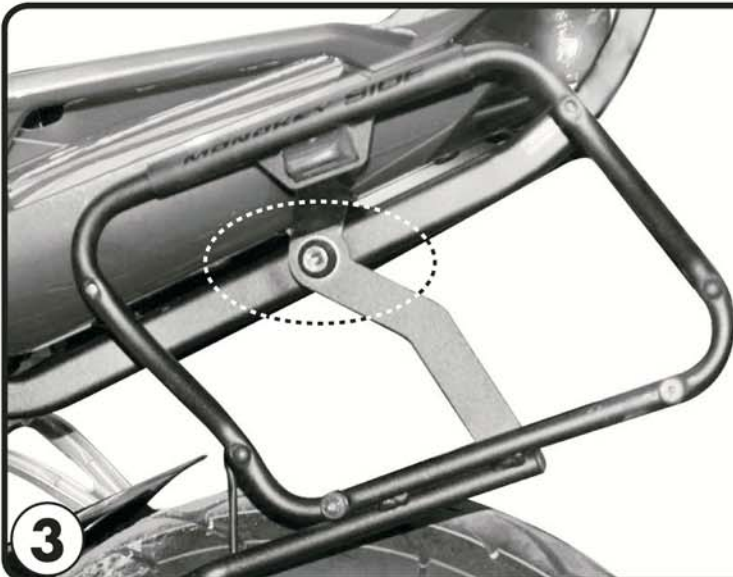

VITE NASCOSTA

LA VITE NASCOSTA IMPEDISCE LO SMONTAGGIO DEL PLXR QUANDO LA VALIGIA E' MONTATA

HIDDEN SCREW

THE HIDDEN SCREW DOES NOT ALLOW THE PLXR TO BE REMOVED WHEN THE CASE IS MOUNTED

VIS CACHEE

LA VIS CACHEE EMPECHE LE DEMONTAGE DU PLXR QUAND LA VALISE EST MONTEE.

DIE SCHRAUBE IST VERSTECKT

DIE VERSTECKTE SCHRAUBE ERMÖGLICHT KEINE DEMONTAGE DES PLXR WENN DER KOFFER MONTIERT IST.

TORNILLO OCULTO

EL TORNILLO OCULTO IMPIDE PODER DESMONTAR EL PLXR CUANDO LA MALETA ESTÀ MONTADA.

PORTAVALIGIE LATERALE SPECIFICO - SPECIFIC TUBULAR SIDE-CASE HOLDER
 PORTE-VALISES LATÉRAUX SPÉCIFIQUE - SPEZIFISCHES STAHLROHR-SEITENTRAEGER
 PORTA MALETAS LATERALES ESPECÍFICO

BMW K1300R
 2009

ISTRUZIONI DI MONTAGGIO - MOUNTING INSTRUCTIONS
 INSTRUCTIONS DE MONTAGE - BAUANLEITUNG - INSTRUCCIONES DE MONTAJE

I ISTRUZIONI DI MONTAGGIO

1. SMONTARE LE FRECCHE E MONTARLE SUL PORTAFRECCHE N°5;
2. MONTARE I SUPPORTI N°2 AI SUPPORTI DELLE PEDALINE PASSEGGERO COME INDICATO IN FIGURA A;
3. FISSARE I SUPPORTI N°3 ALLE MANIGLIE ORIGINALI (FIGURA B) ED IL PONTE N°4 SOTTO IL CODONE DELLA MOTO COME MOSTRA LA FIGURA C;
4. TERMINARE IL MONTAGGIO ASSICURANDOSI CHE TUTTE LE VITI SIANO SERRATE BENE (VITI M6=9.6NM, VITI M8=23NM).

GB MOUNTING INSTRUCTIONS

1. DISASSEMBLE THE REAR LIGHTS AND MOUNT THEM ON THE REAR LIGHT HOLDERS N°5;
2. SET THE SUPPORTS N°2 TO THE PASSENGER FOOTREST'S AS YOU CAN SEE FROM PICTURE A;
3. FIX THE SUPPORTS N°3 TO THE ORIGINAL HANDLES (PICTURE B) AND THE BRIDGE N°4 UNDER THE BIG TAIL OF THE MOTORCYCLE AS YOU CAN SEE FROM PICTURE C;
4. CHECK THAT ALL THE SCREWS ARE WELL TIGHTENED (SCREWS M6=9,6Nm - SCREWS M8=23Nm).

F INSTRUCTIONS DE MONTAGE

1. DEMONTER LES CLIGNOTANTS D'ORIGINE ET LES MONTER SUR LES PORTE-CLIGNOTANTS N°5;
2. MONTER LES SUPPORTS N°2 AUX PLATINES DES REPOSE-PIEDS PASSAGER COMME INDIQUE EN PHOTO A;
3. FIXER LES SUPPORTS N°3 AUX POIGNEES (PHOTO B) ET LE PONT N°4 SOUS L'ARRIERE DE LA MOTO COMME ILLUSTRE EN PHOTO C;
4. TERMINER LE MONTAGE EN CONTROLANT LE BON SERRAGE DE TOUTES LES VIS (VIS M6=9,6Nm - VIS M8=23Nm).

D BAUANLEITUNG

1. DEMONTIEREN SIE DIE BLINKER UND MONTIEREN SIE DIESE AUF DEM BLINKERTRAGER N°5;
2. MONTIEREN SIE DIE HALTERUNGEN N°2 AN DEN FUßRASTERN WIE IM BILD A GEZEIGT;
3. BEFESTIGEN SIE DIE HALTERUNGEN N°3 AN DEN ORIGINAL HANDGRIFFEN (BILD B) UND DIE BRÜCKE N°4 UNTER DEM HECK DES MOTORRADS WIE IM BILD C GEZEIGT;
4. ZULETZT ÜBERPRÜFEN SIE DASS ALLE SCHRAUBEN (SCHRAUBEN M6=9.6NM, SCHRAUBEN M8=23NM) FESTGEZOGEN WURDEN.

ES INSTRUCCIONES DE MONTAJE

1. DESMONTAR LOS INTERMITENTES Y MONTARLOS EN EL SOPORTE N. 5
2. MONTAR LOS SOPORTES N2 A LOS SOPORTES DE LOS ESTRIBOS DEL PASAJERO COME SE INDICA EN LA FOTO A
3. FIJAR LOS SOPORTES N3 A LOS ASIDEROS ORIGINALES (FOFOB) Y LA REFERENCIA N4 BAJO EL COLIN DE LA MOTO COMO SE MUESTRA EN LA FOTO C;
4. TERMINAR EL MONTAJE VERIFICANDO QUE TODOS LOS TORNILLOS ESTÉN BIEN APRETADOS ((TORNILLOS M6=9,6NM - TORNILLOS M8=23NM).