

BF13K

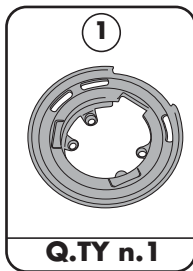

Q.TY n.1



COMPONENTI ORIGINALI
ORIGINAL PARTS
PARTES ORIGINALES
ORIGINAL BAUTEILE
COMPONENTES ORIGINALES

Q.TY n.-

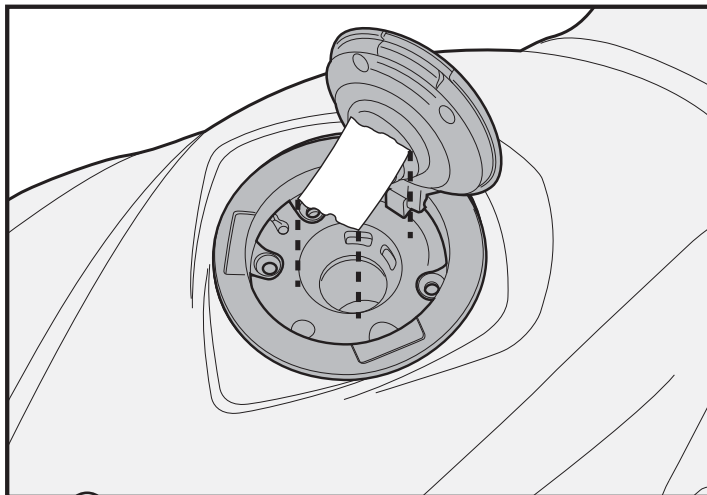

. PRIMA DI PROCEDERE APPLICARE DELLO SCOTCH SUL FORO DEL SERBATOIO PER EVITARE DI FARVI CADERE ACCIDENTALMENTE DELLE VITI.

. BEFORE STARTING, APPLY SOME ADHESIVE TAPE TO CLOSE THE TANK HOLE TO PREVENT SCREWS FROM FALLING INSIDE IT

. AVANT DE COMMENCER, APPLIQUEZ UN PEU DE RUBAN SUR LE RESERVOIR POUR EVITER LA PERTE DE VIS

. BEVOR SIE BEGINNEN, GELTEN ETWAS KLEBEBAND AUF DEM TANK, UM DEN VERLUST VON SCHRAUBEN VERMEIDEN

. ANTES DE COMENZAR, APLIQUE UN POCO DE CINTA EN EL TANQUE PARA EVITAR LA PÉRDIDA DE LOS TORNILLOS

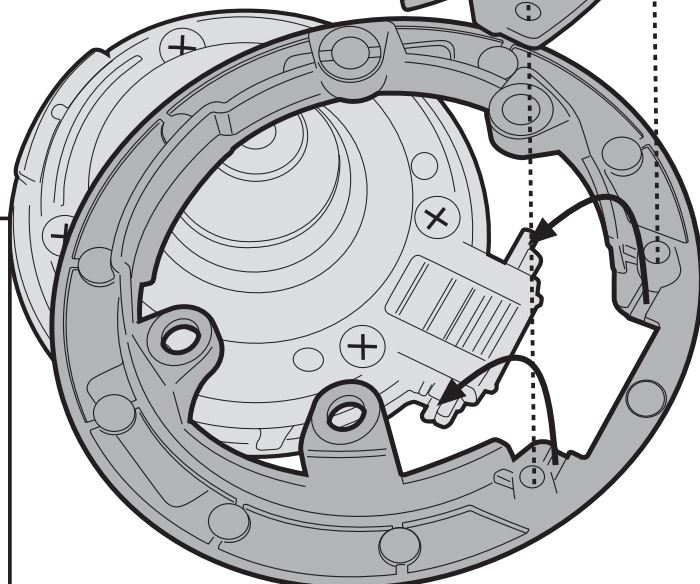
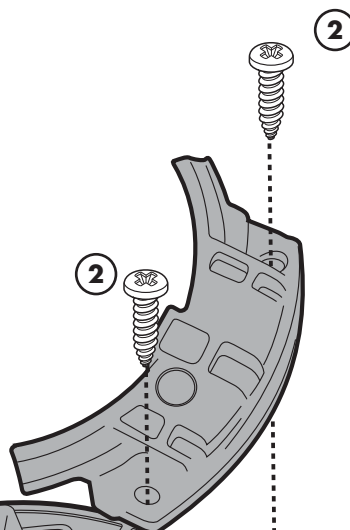
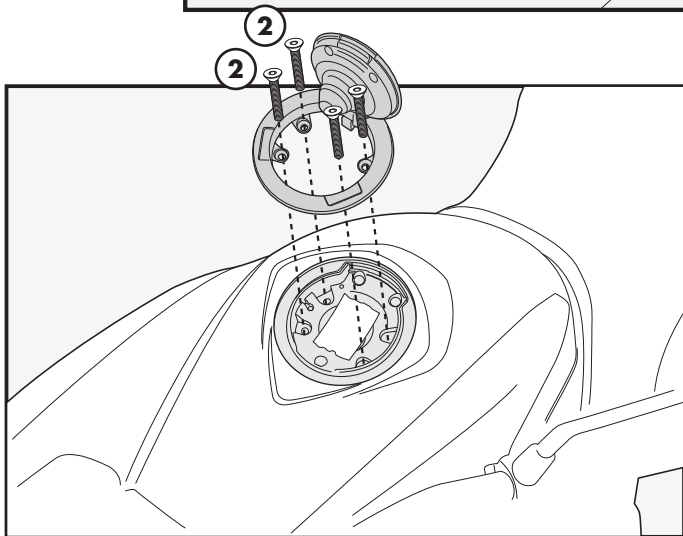

Svitare e smontare il tappo del serbatoio dalla ghiera originale

Unscrew and remove the original cap of the tank

Dévisser et enlever le bouchon d'origine du réservoir

Lösen und entfernen Sie die ursprüngliche Deckel des Tanks

Destornille y quite la tapa original del depósito

BF13K

